



ADEMCO Via 30+

SECURITY SYSTEM

Installation Instructions

CONGRATULATIONS!

On Your Purchase of the Ademco via30+

The purpose of these Installation Instructions is to give you a complete overview of the system, and provide instructions for installing a basic system.

CONTACTING TECHNICAL SUPPORT

PLEASE,

Before you call Technical Support, be sure you:

- **READ THE INSTRUCTIONS!**
- **Check all wiring connections.**
- **Determine that the power supply and/or backup battery are supplying proper voltages.**
- **Verify your programming information where applicable.**
- **Note the proper model number of this product, and the version level (if known) along with any documentation that came with the product.**
- **Note your ADEMCO customer number and/or company name.**

Having this information handy will make it easier for us to serve you quickly and effectively.

You may contact Technical Support via Toll Free Fax. Please include your return fax number. You will receive a reply within 24 hours. You may also contact Technical Support via modem to ATLLIS-BBS, Tech Support's Electronic Bulletin Board System. Replies are posted within 24 hours.

East Coast Technical Support: 1-800-645-7492 (8 a.m.-6 p.m. E.S.T.)

West Coast Technical Support: 1-800-458-9469 (8 a.m.-5 p.m. P.S.T.)

Technical Support Fax Number: 1-800-447-5086

ATLLIS-BBS Electronic Bulletin Board System: 1-516-496-3980

(1200 - 9600 Baud, 8 Data Bits, 1 Start/Stop Bit, No Parity)

**The Ademco via30+ System
Can Support 2 EOLR Wired Zones
and
(when used with an appropriate wireless receiver and/or wired expansion module)
Up to a Total of 30 Expansion Zones
(Comprising any combination of: up to 30 Wireless and/or up to 8 Additional Wired Zones)
and
(when used with an appropriate output relay module)
Up to 4 Output Relays**

**The System Can Also Support:
Telephone Voice Module (No. 4285)
and
Long Range Radio Reporting (via No. 7720ECP)**

**FOR YOUR CONVENIENCE,
a Programming Form
has been included at the center of this manual.**

TABLE OF CONTENTS

Section 1. GENERAL INFORMATION.....	4	Section 6. SYSTEM COMMUNICATION.....	30
Introduction	4	Report Code Formats	30
Zone Characteristics.....	5	Section 7. REMOTE PROGRAMMING AND	CONTROL (DOWNLOADING).....
Section 2. SYSTEM CONFIGURATIONS.....	6	General Information.....	32
HARD WIRED ZONES.....	6	Equipment Required.....	32
Zones 5&6 (Basic Control's Zones)	6	Programming.....	32
WIRED ZONE EXPANSION	7	Remote Programming Advisory Notes.....	32
Nos. 4219 and 4229 Expansion Modules.....	7	Section 8. SYSTEM OPERATION.....	33
WIRELESS EXPANSION, -5700 & 5800 RF SYSTEMS-...	8	SECURITY CODES.....	33
General.....	8	Master Code.....	33
Supervision.....	8	User Codes.....	33
House Identification.....	9	KEYPAD FUNCTIONS	33
Transmitter Identification.....	9	General Information.....	33
RF System Installation Advisories	9	Arming Functions	34
5800 System Transmitter Installation Options.....	10	Panic Keys	34
RELAY OUTPUTS.....	11	Relay Outputs (if used).....	34
Nos. 4204 and 4229 Output Relay Modules.....	11	Exit Alarm Displays (if programmed).....	35
4204 Setup	11	TROUBLE CONDITIONS.....	35
4229 Setup	11	General Information.....	35
Section 3. MOUNTING THE CONTROL,	LOCK, & PC BOARD	"Check" and "Battery" Displays	35
Mounting the Cabinet	12	Power Failure.....	35
Installing the Lock (if Used).....	12	Other Displays (Fixed Word Consoles).....	35
Installing the Control's Circuit Board Alone,	or (if used), with a 4219, 4229, or 4204.....	Section 9. TESTING THE SYSTEM.....	36
Installing Control and RF Receiver Circuit Boards	Together, in the Same Cabinet	Procedure.....	36
Using Optional Voice Module or Long Range Radio....	13	Section 10. SPECIFICATIONS &	ACCESSORIES
Section 4. WIRING & POWERING	THE SYSTEM	SPECIFICATIONS.....	39
Grounding the System.....	14	ACCESSORIES (COMPATIBLE DEVICES).....	41
Terminals and Connections	14	FCC STATEMENTS.....	48
Power-up Procedure	15	CANADIAN DOC STATEMENT.....	49
Section 5. PROGRAMMING THE SYSTEM.....	16	CSFM 24 HR BATTERY BACK-UP.....	49
General Information	16	LIMITATIONS OF THIS ALARM SYSTEM	50
Summary of Programming Commands.....	17	INDEX.....	51
Special Messages.....	17	LIMITED WARRANTY.....	52
PROGRAMMING DATA FIELDS.....	18	<u>Diagrams and Tables</u>	
Zone Response Type Definitions (under field *56)	20	TROUBLESHOOTING GUIDE.....	37
Relay Basics (under field *80).....	24	OUTPUT RELAY EXAMPLES TABLE.....	44
ALPHA DESCRIPTION ENTRIES.....	27	DIP SWITCH TABLES FOR	WIRELESS DEVICES.....
Assigning Zone Descriptors.....	27	SUMMARY OF CONNECTIONS DIAGRAM.....	47
Entering Zone Descriptors.....	27	PROGRAMMING FORM.....	Centerfold
Adding Custom Words.....	28		
ALPHA FIXED DICTIONARY	(For Entering Zone Descriptors).....		
CHARACTER (ASCII) CHART	29		

Section 1. GENERAL INFORMATION

Introduction

System	The Ademco via30+ is a microprocessor-based state-of-the-art security control intended for wireless as well as wired zone applications.
Zones Supported	Supports up to 32 zones, in the following configuration: <ul style="list-style-type: none"> • 2 hard wired EOLR "basic" zones. • Up to 30 expansion zones (wireless and/or additional wired zones) by using an appropriate RF receiver (4281 or 5881 type) or wired expansion module (No. 4219 or 4229). Refer to the Zone Characteristics tabulation on the next page for detailed zone information. <p>Note: The single 4281/5881 type RF receiver that the Ademco via30+ accommodates, features Spatial Diversity (dual antennas), which virtually eliminates the possibility of "Nulls" and "Dead Spots" within the coverage area.</p>
Relay Outputs	2 or 4 output relays can be added, to perform programmable actions in response to zone activity or manual entries, by using a No. 4229 Wired Expansion/Relay Module (8 wired zones and 2 output relays) or No. 4204 Relay Module (4 output relays).
Programming	A No. 5137AD or 6139 Alpha Console is required for programming zones and relay operation , but it need not remain in the system. These consoles have digital keypads and 2-line 32 character alphanumeric LCDs (Liquid Crystal Displays). Programmed options to establish specific alarm and reporting features are stored in electrically erasable, non-volatile EEROM memory. This means that the unit can be reprogrammed many times (unlike units equipped with PROMs) and that information which has been programmed will not be lost during a complete loss of power. In addition, the system can be uploaded, downloaded, or controlled via a computer and Hayes modem (see REMOTE PROGRAMMING AND CONTROL on page 32).
Remote Consoles	After programming, the system may use one or more <u>4127</u> , <u>4137AD</u> , 5137AD, <u>6127</u> , <u>6128</u> , <u>6137</u> , 6138, or 6139 Consoles. The underlined models have fixed English status LCDs. The others have alphanumeric displays. <p>Note: Nos. 4137AD, 5137AD, 6128, 6137, 6138, and 6139 are Addressable Consoles and must be set to their non-addressable mode (device ID 31).</p> When wireless is in use, the system may also be armed and disarmed with a wireless keypad (No. 5727/5827) or other 5800 RF button type transmitters (e.g., Nos. 5801, 5802, 5803, 5827BD).
Voice Module	A No. 4285 Voice Module can be connected to the system. It enables Touch-tone telephones to control, and receive messages from, the system remotely. <i>Addressable type consoles must be used (not 4127 or 6127).</i>
User Codes	Up to 6 secondary user codes can be assigned by the system's Master code.
Communication	Communication capability (central station reporting, voice module accommodation, etc.) over existing phone lines is provided. An output for optional Long Range Radio is also provided.

Alarm Output Advisory

This system includes an alarm output rated at 2 amps. **Throughout the manual, wherever reference is made to Alarm Output Ratings, they assume a fully charged battery is connected, unless the UL rating is stated.** The battery is periodically tested automatically (approximately every four hours), and if it cannot sustain a load, a low battery message is displayed and can be reported to the central station.

Multiple Consoles

(up to 4) may be used, as long as their total current drain is within the alarm and auxiliary power output limitations described in the **SPECIFICATIONS AND ACCESSORIES** section.

Zone Characteristics

Zones 1-4	<i>not present</i>										
Zones 5,6 For more information, see page 6.	Wired Programmable Zones. EOLR supervised, N.O. or N.C. sensors, 300-500 msec normal response.										
Zones 7, 95, 96 For more information, see page 34.	Console Panics (Wired & Wireless). 24hr zones, programmable for silent, audible, auxiliary, or fire.										
Zone 8	Duress (see User's Manual).										
Zone 9	Tamper. Reports faults in the relay module and expansion units (e.g., 4204, 4219, 4229, 4281, 5881). For all report formats (except Contact ID, which provides more explicit reporting) a trouble code is reported when the system is not armed, and Zone 9 report code is sent for an alarm.										
Additional Wired Programmable Zones For more information, see page 7.	Up to 8 loops can be added, with a 4219 Wired Expansion Module or No. 4229 Wired Expansion/Relay Module. Loops are EOLR supervised, for N.O. or N.C. sensors, 300-500 msec normal response, with optional fast (10-15 msec) response on loop A (first expansion zone). Zone numbers 10-17 should be assigned when using a 4219 or 4229 for zone expansion.										
Wireless Zones For more information, see pages 8-10.	<p>Up to 30 wireless (RF) zones can be added by using an Ademco 4281(5700 System) or 5881 (5800 System) Type RF Receiver. Specifically:</p> <table border="0"> <thead> <tr> <th><u>Model</u></th> <th><u>Number of Zones</u></th> </tr> </thead> <tbody> <tr> <td>4281L</td> <td>Up to 4</td> </tr> <tr> <td>4281M/5881L</td> <td>Up to 8</td> </tr> <tr> <td>5881M</td> <td>Up to 16</td> </tr> <tr> <td>4281H/5881H</td> <td>Up to 30</td> </tr> </tbody> </table> <p>Zone number assignments (which are also transmitter ID assignments for 5700 RF system transmitters) can be in the 10-63 range (18-63 when a 4219 or 4229 is also used). A variety of RF system transmitters can be used to make up the wireless zones. This includes window/door units, smoke detectors, PIRs, and panic keys.</p> <p>Note: For brevity, subsequent references herein to the RF Receiver will be indicated by "4281/5881" unless a specific model is named.</p>	<u>Model</u>	<u>Number of Zones</u>	4281L	Up to 4	4281M/5881L	Up to 8	5881M	Up to 16	4281H/5881H	Up to 30
<u>Model</u>	<u>Number of Zones</u>										
4281L	Up to 4										
4281M/5881L	Up to 8										
5881M	Up to 16										
4281H/5881H	Up to 30										

If (4219/4229) wired expansion zones and (4281/5881) wireless expansion zones are to be added, they can comprise up to 8 (4219/4229) wired zones, plus wireless zones up to the number permitted by the type of 4281/5881 RF receiver used, as long as the total does not exceed the 30 expansion zones accommodated by the control.

For example: When all 8 loops of a 4219 or 4229 are to be used, a 4281H or 5881H can add only 22 zones, so as not to exceed a total of 30 expansion zones for this control.

Section 2. SYSTEM CONFIGURATIONS

HARD-WIRED ZONES

**Zones 5&6
(Basic Control's Zones)**

The *Ademco via30+* supports 2 hard-wired zones, which are connected as zones 5 & 6 (zones 1 – 4 are not present in this system). These zones must be EOLR supervised, and can use N.O. and/or N.C. sensors.

Zone Response Type	Any zone response can be assigned to devices on these zones except Supervised Fire (09), which can be assigned only to zone 5 (see below).
Response Time	300–500 msec.
Max. Zone Resistance	300 ohms, excluding EOLR
EOLR Supervised	<ul style="list-style-type: none"> • Supports both open circuit and closed circuit devices. • Connect open circuit devices in parallel across the loop. The 1,000 ohm EOLR must be connected across the loop wires at the last device. <i>Important:</i> If the EOLR is not at the end of the loop, the zone is not properly supervised. The system may not respond to an open circuit within the zone. • Connect closed circuit devices in series with the HI side of the loop.
EOLR Fire Zone 5	<ul style="list-style-type: none"> • Of the 2 hard-wired zones, only zone 5 can be used for fire. • Supports as many 4-wire smoke detectors as can be powered. • The zone must be configured for EOLR supervision. • The detectors must be wired in parallel, with the EOLR at the last detector for full supervision. • To supervise power, a supervisory module (e.g., System Sensor No. A77-716B EOL Relay Module) is required.

WIRED ZONE EXPANSION

Nos. 4219 and 4229 Expansion Modules

If a No. 4219 Wired Expansion Module, or 4229 Wired Expansion/Relay Module is used, 8 wired EOLR zones can be added to the basic control's 2 zones, for a total of 10.

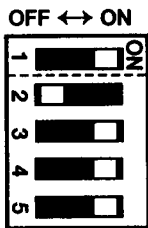

Location	Can be mounted within or outside of the <i>Ademco via30+</i> cabinet (see page 12).
Connections	Connects to the control's remote console terminals for signaling.
Supervision	<ul style="list-style-type: none"> Supervised against removal. Has tamper protection for security when mounted outside of the cabinet.
Zone Information	<ul style="list-style-type: none"> Eight wired expansion loops (designated A to H) should be assigned zone numbers 10-17, and any or all can be programmed individually (in field *56). If RF will be used in addition to one of these units (see <i>WIRELESS EXPANSION</i> sections), any zone numbers in the range of 18-63 (<i>not</i> 10-17) should be chosen for the RF zones, <i>even if some of the unit's wired expansion loops are not being used.</i> <p>For example:</p> <p>If only four of the wired expansion loops are being used, a 4281H or 5881H RF Receiver could add 26 RF zones (using any zone numbers in the range of 18-63) to the system, for a combined total of 30 expansion zones.</p> <p>If a 4219 or 4229 is <i>not</i> being used, however, the same receiver could add 30 RF expansion zones to the system, assigned <i>any</i> zone numbers within a 10-63 range.</p>
Settings	The 4219's or 4229's DIP switch must be set for a device address of "1", as described in its instructions (bottom 3 switches to the RIGHT..."on", and the next switch above to the LEFT..."off"). Switch 1 determines zone A's response time ("ON" = normal response, "OFF" = fast response).

For additional information, see the instructions that accompany the 4219 and 4229.

WIRELESS EXPANSION — 5700 & 5800 RF SYSTEMS —

General In addition to its basic wired zones, the control, in conjunction with an appropriate 5700 or 5800 system RF Receiver, can support up to the number of wireless zones shown below.

5700 SYSTEM	
RF Receiver	No. of Zones
4281L	up to 4
4281M	up to 8
4281H	up to 30†

5800 SYSTEM	
RF Receiver	No. of Zones
5881L	up to 8
5881M	up to 16
5881H	up to 30†

† In *this* application

A wireless keypad can also be used with the system (No. 5727 with 5700 System, No. 5827 with 5800 System, No. 5827BD with either system).

The receiver recognizes status messages and keypad control messages from Wireless Transmitters operating at 345MHz (315MHz for the 5700 system's Canadian version). These messages are processed and relayed to the control panel via a 4-wire connection to the control's remote console terminals. The receiver's RED, BLACK, YELLOW, and GREEN wires are connected in parallel with console wiring.

The receiver can be mounted within the control's cabinet (see page 13) or installed remotely, in its own housing. It can detect signals from wireless transmitters within a nominal range (installed) of 200 feet.

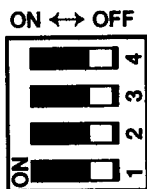

The receiver's DIP switch must be set for a device address of "0", as described in its instructions (all switches to the RIGHT... "off").

Supervision

Except for transmitters that may be carried off-premises (such as the 5700 system's 5701 and 5727, the 5800 system's 5802, 5802CP, 5803, and 5827, and either system's 5827BD), each transmitter is supervised by a check-in signal that is sent to the receiver at 70-90 minute intervals. If at least one check-in is not received from each *supervised* transmitter within a 12 hour period, the "missing" transmitter number(s) and "CHECK" will be displayed on the console.

The supervision for a particular transmitter in the 5800 system may be turned off by learning it as a "UR" (unsupervised RF) type, as described later.

Each transmitter is also supervised for low battery and will transmit a low battery signal to its receiver, with the battery having at least 30 days of life remaining. A low battery message and appropriate zone number will appear on a wired console's display.

If a 5727, 5827, or 5827BD wireless keypad transmits and has a low battery, it will be displayed as Zone 00.

Note: After a low or dead battery is replaced, activate the transmitter and then enter the security code + OFF to clear the system's memory of the "Low Battery" signal.

Some transmitters (e.g., 5800 system's 5802, 5802CP, and 5803) contain long-life but non-replaceable batteries. At the end of their life, the complete unit must be replaced [and new identification code(s) learned by the control...see *Transmitter Identification* below].

The receiver itself is supervised. A tamper report (zone 9) will be generated:

- a) If communication with the receiver is interrupted.
- or
- b) If valid RF signals are not received within 12 hours from at least one *supervised* wireless transmitter (if any are included in the system).

WIRELESS TRANSMITTERS are described on page 41.
TRANSMITTER & WIRELESS KEYPAD DIP SWITCH SETTING TABLES are shown on page 46.

House Identification

5700 SYSTEM	5800 SYSTEM
<p>The 4281 responds only to transmitters set to the same House ID (01-31, per the DIP switch tables on page 46) as programmed in the control's field *24. This prevents interference from transmitters in other nearby systems. To make sure that a House ID is chosen that is not in use nearby, conduct the Sniffer Mode test described under <i>TESTING THE SYSTEM</i>.</p>	<p>If a 5827 or 5827BD Wireless Keypad is to be used with the system, a House ID Code (01-31) must be set in programming field *24 to establish proper communication, and the keypad should be set to the same ID. If no keypad is to be used, field *24 should be 00. <i>DIP switch setting information for a 5827 is given on page 46. The 5827BD is keypad programmable.</i></p>

Transmitter Identification

5700 SYSTEM	5800 SYSTEM
<p>Each transmitter's assigned zone number is DIP switch programmable in the unit as its transmitter ID (except wireless keypads, which are fixed at ID 00). Whenever a transmission takes place, whether for a fault, check-in, or low battery, the ID number is sent along with the message to the 4281 which, in turn, relays this information to the control, which displays the condition and zone number on the console. <i>The 5827BD Wireless Keypad is keypad programmable.</i></p> <p>Certain IDs in the assignment range of 10-63 have the following characteristics:</p> <p>Transmitters set for IDs of 32-47 will have a 3 minute lock-out between fault transmissions to conserve battery life (normally PIR units, but transmitters protecting <i>frequently used</i> doors and windows should also be set for IDs in this range).</p> <p>Transmitters set for IDs of 48-55 (FIRE) will transmit once every 12 seconds while the zone is faulted. <i>This and the next range of zone numbers have high signal priority and their frequent transmissions while faulted insure retriggering of the alarm until the cause is removed.</i></p> <p>Transmitters set for IDs of 56-63 will transmit once every 3 seconds while faulted.</p> <p>Transmitter IDs of 62 and 63 are unsupervised to allow removal of the 5701 off-premises. Signal priority is higher than burglary.</p>	<p>Each transmitter <i>input</i> has a different ID (identification) code, part of which includes a unique serial number permanently assigned to the device during manufacture. Many transmitters have more than one input, hence ID code (e.g., 5801 has 4, 5803 has 3, 5816 has 2, etc.) <i>and each input requires a separate programming zone.</i></p> <p>It is not necessary to assign a transmitter's ID(s) during installation. Instead, the control must learn or be programmed for each transmitter's ID code(s) during programming, in conjunction with assigned zone number(s) and other data. Whenever a transmission takes place, whether for a fault, check-in, or low battery, the ID code is sent as part of the message to the 5881. In turn, the information is relayed to the control, which displays the condition and associated zone number on the console.</p>

RF System Installation Advisories

1. If the Receiver is to be mounted remotely (not in the control's cabinet), place it in a high, centrally located area for best reception.
2. Do not locate receiver or transmitters on or near metal objects. This will decrease range and/or block transmissions.
3. Do not locate receiver in an area of high RF interference (revealed by frequent or prolonged lighting of the LED in the receiver...random flicker is ok).
4. Before mounting transmitters permanently, conduct Go/No Go Tests to verify adequate signal strength (see *TESTING THE SYSTEM*) and reorient or relocate transmitters if necessary.

5800 System Transmitter Installation Options

To install the particular transmitters in a 5800 system, one of two optional methods can be used. Option 1, whose procedure is described in general below, and in detail in *PROGRAMMING THE SYSTEM* on page 16, involves having the system learn each transmitter to be used in the system. Option 2, described below, involves the downloader, where the IDs can be entered manually at the office and then downloaded to an operating system.

OPTION 1

Learning and Assigning ID Codes at the Control

With each transmission, each transmitter sends an ID code which includes, in part, that device's unique factory assigned serial number. Some devices have more than one input (sensor point) and that input is also part of the ID code. Each ID code must be learned and assigned individually to the zone with which it will be associated.

During programming of the zone, after the device type is entered, the display "Learn S/N?" will appear. To have the control learn the ID then, pressing [1] will result in the display "TRANSMIT NOW".

The control program is now poised at a zone number to be assigned a particular transmitter input (e.g., of a multi-point contact, single-point motion detector, single-point smoke detector, multi-point emergency transmitter, etc.). A transmitter will either be *already* installed, or one of a group of transmitters *to be* installed at a given site.

The appropriate transmitter input (point) is then activated to cause a complete event transmission (e.g., by opening and closing a contact, closing and opening a contact, pressing and releasing a button, causing alarm and restore, etc.).

If the ID code of this first transmission event was previously learned, a single, long error sound is emitted.

If the ID code of this first transmission was not previously learned, the assignment of zone number and ID code (which includes device serial number and sensor point) is stored in the control memory, and the console emits a single, short sound to acknowledge this fact and to request a duplicate transmission to verify the assignment.

A second transmission should then be initiated. Upon reception of a second transmission, the control compares this second (verify) event with the first (learn) event.

- a) If the two events match, the control keeps the assignment in EEPROM memory and the console emits a double, short, acknowledge sound. The "learned" ID code, together with other system attributes associated with the particular zone are thus assigned to the selected zone number for that transmitter's sensor point.
- b) If the second (verify) transmission does not match the first (learn) transmission, the control awaits another transmission to match the most recently received one. If another matching transmission is not forthcoming, (within a pre-determined time limit), the assignment is discarded.

OPTION 2

Manual ID Code Assignment Method

Supplements *REMOTE PROGRAMMING AND CONTROL (DOWNLOADING)* section on page 32.

At the downloader computer location, the downloader for the **Ademco via30+** is brought up.

The identification code numbers can be entered at the screens where the zone characteristics and communicator reporting codes are entered. If the 5800 RF system has been properly selected (RF expander type 5881) on a previous screen, the type of transmitter and identification code [which includes input (loop) data...see pages 42 and 43] can be entered on the same line as the other items for each zone. The factory pre-recorded serial number is read from the non-removable portion of the transmitter case in a 7-decimal digit (telephone number) format.

Mark the transmitters to be used in the installation (multi-point contact, single-point motion detector, single point smoke detector, multi-point emergency sensor, etc.) and enter their ID codes when programming other data for the system. When the data that defines the system is downloaded, the identification codes will be downloaded also and stored in EEPROM memory.

RELAY OUTPUTS

Nos. 4204 and 4229 Output Relay Modules

The *Ademco via30+* can support relay outputs via the use of either a 4204 (4 outputs) or a 4229 (2 outputs). These modules provide form C (normally open and normally closed) dry contacts on relays that can be programmed to activate or deactivate to perform some action in response to a predetermined event such as turning on lights and/or closing a fire door in the event of a fire alarm condition. There are many different uses for these relays, some of which are suggested in the table on page 44.

The unit can be located inside the control's cabinet or remotely (see *MOUNTING THE CONTROL, LOCK, & PC BOARD* section and the instructions that accompany the unit).

4204 Setup

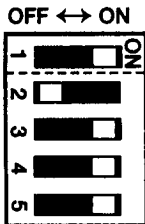

The 4204 Relay Module has 4 Form C relays. Each relay can be used independently for different functions. The following steps should be taken to properly set up the 4204:

1. **Connect the 4204 to the control's remote console terminals** (4-7), using standard 4-conductor twisted cable (for long wiring runs) or the connector supplied with the 4204 (as shown in the *Summary of Connections* diagram).
2. **Set the 4204's DIP switch for a device address of "1"** (switch 2 "OFF" and switches 3, 4, 5 "ON"). Switch 1 determines the unit's cover tamper response ("ON" = disabled, "OFF" = enabled).

Note: Some "early" units have only a 4-position DIP switch.

Set 1 to "OFF" and 2, 3, 4 to "ON".

3. **During programming** (summarized here, but see the detailed procedure in the *PROGRAMMING THE SECURITY CONTROL* section):
 - a. Program a "3" in field *25.
 - b. Program fields *80 (Output Relays) and *81 (Zone Lists) for the desired relay responses.
4. **Connect the desired field wiring** to the unit's relay contact terminals.

4229 Setup

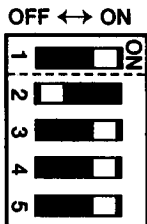

The 4229 Wired Expansion/Relay Module has 8 hard-wired zones and 2 Form C relays. Each relay can be used independently for different functions. The following steps should be taken to properly set up the 4229:

1. **Connect the 4229 to the control's remote console terminals** (4-7), using standard 4-conductor twisted cable (for long wiring runs) or the connector supplied with the 4229 (as shown in the *Summary of Connections* diagram).
2. **Set the 4229's DIP switch for a device address of "1"** (switch 2 "OFF" and switches 3, 4, 5 "ON"). Switch 1 determines zone A's response time ("ON" = normal response, "OFF" = fast response).
3. **During programming** (summarized here, but see the detailed procedure in the *PROGRAMMING THE SECURITY CONTROL* section):
 - a. Program a "2" in field *25.
 - b. Program fields *80 (Output Relays) and *81 (Zone Lists) for the desired relay responses.
 - c. In field *56 (zone programming), assign zone numbers 10-17 to the 4229's wired expansion zones.
4. **Connect the desired field wiring** to the unit's relay contact terminals.

Output Relay Advisory

If a relay is energized before a wired smoke detector is reset, the relay will be stopped by the interruption of Aux. Power that resets the smoke detector. If this is not desired, the power to the relay module should be supplied from another 12V power source (e.g., the same source that is powering external equipment through the relay contacts).

Section 3. MOUNTING THE CONTROL, LOCK, & PC BOARD

Mounting the Cabinet

The *Ademco via30+* is supplied with a 12-1/2" (318mm) wide x 14-1/2" (368mm) high x 3" (76mm) deep cabinet suitable for use in residential installations.

Mount the control cabinet to a sturdy wall using fasteners or anchors (not supplied) in a clean, dry area which is not readily accessible to the general public. 4 mounting holes are provided at the back of the cabinet.

Installing the Lock (If Used)

The cabinet can be closed and secured *without* a lock by using 2 screws in the cover's edge.

Use an Ademco No. N6277 Cam Lock and No. N6277-1 Push-On Clip (Retainer Clip).

1. Remove the cabinet cover. *It is easily removable for servicing and is easily reinstalled.*
2. Remove the lock knockout from the control cabinet cover. Insert the key into the lock. Position the lock in the hole making certain that the latch will make contact with the latch bracket when the door is closed.
3. While holding the lock steady, insert the retainer clip into the retainer slots. Position clip as illustrated to facilitate easy removal.

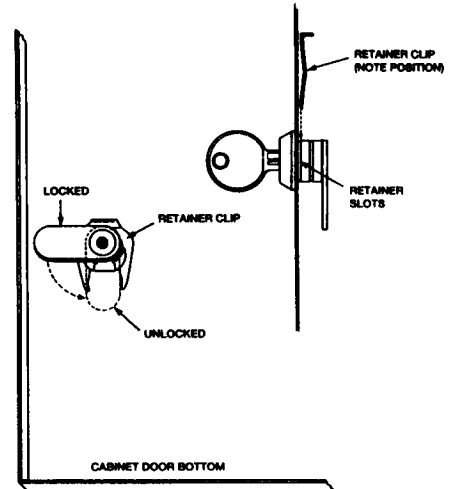

Installing the Control's Circuit Board Alone, or (if used), with a 4219, 4229, or 4204

IMPORTANT!
Before installing the cabinet's contents, be sure to remove the appropriate metal cabinet knockouts.
DO NOT ATTEMPT TO REMOVE THE KNOCKOUTS AFTER THE CIRCUIT BOARD HAS BEEN INSTALLED.

Control's Circuit Board

1. Hang two *long* mounting clips (provided) on the raised cabinet tabs (see Detail B below).
2. Insert the top of the circuit board into the slots at the top of the cabinet. Make sure that the board rests on the correct row (see Detail A).
3. Swing the base of the board into the mounting clips and secure the board to the cabinet with the accompanying screws (see Detail B).

4219, 4229 or 4204

1. Insert self-tapping screws (provided) in two adjacent raised cabinet tabs. Leave the heads projecting 1/8".
2. Hang the unit on the screw heads via two of the slotted holes at the rear of its housing, as shown.
3. The 4219's or 4229's cover can be left off if the cover tamper jumper is placed in its upper (not tampered) position (see Detail C). The tampered cover is necessary for installations outside of the control's cabinet.

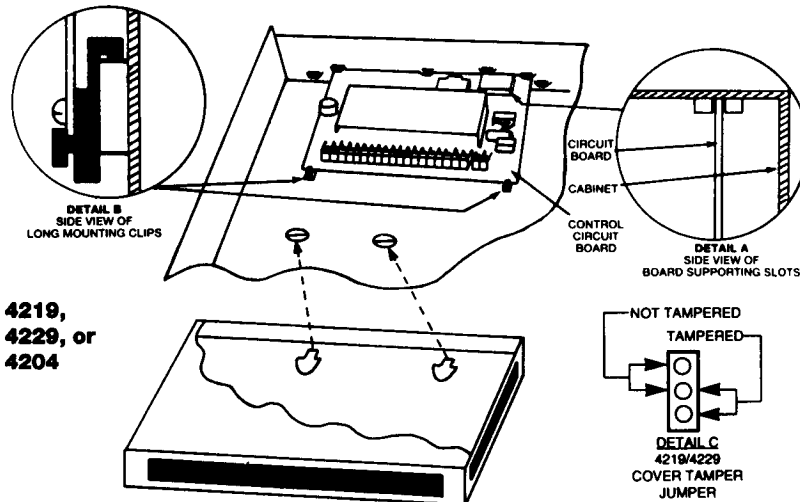

**Installing Control and
RF Receiver
Circuit Boards
Together,
In the Same Cabinet**

IMPORTANT!
Before installing the cabinet's contents, be sure to remove the appropriate metal cabinet knockouts.
DO NOT ATTEMPT TO REMOVE THE KNOCKOUTS AFTER THE CIRCUIT BOARDS HAVE BEEN INSTALLED.

1. Hang two *short* (black) mounting clips (provided with receiver) on the raised cabinet tabs, as shown in Detail B below.
2. Insert the top of the receiver board (removed from its own case as described in *its* instructions) into the slots at the top of the cabinet (see Detail A). Make sure that the board rests on the correct row of tabs.
3. Swing the base of the board into the mounting clips and secure it to the cabinet with the accompanying screws (see Detail B).
4. Insert the top of the control's board into the slot in the clips and position two *long* (red) clips at the lower edge of the board (see Detail C).
5. Swing this board into place and secure it with two additional screws.
6. Insert grounding lugs (supplied with the receiver) through the top of the cabinet into the *left-hand* terminals of the antenna blocks (at the upper edge of the receiver board) and secure them to the cabinet top with the screws provided, as shown in Detail D.
7. Insert the receiver's antennas through the top of the cabinet, into the blocks' *right-hand* terminals, and tighten the screws.

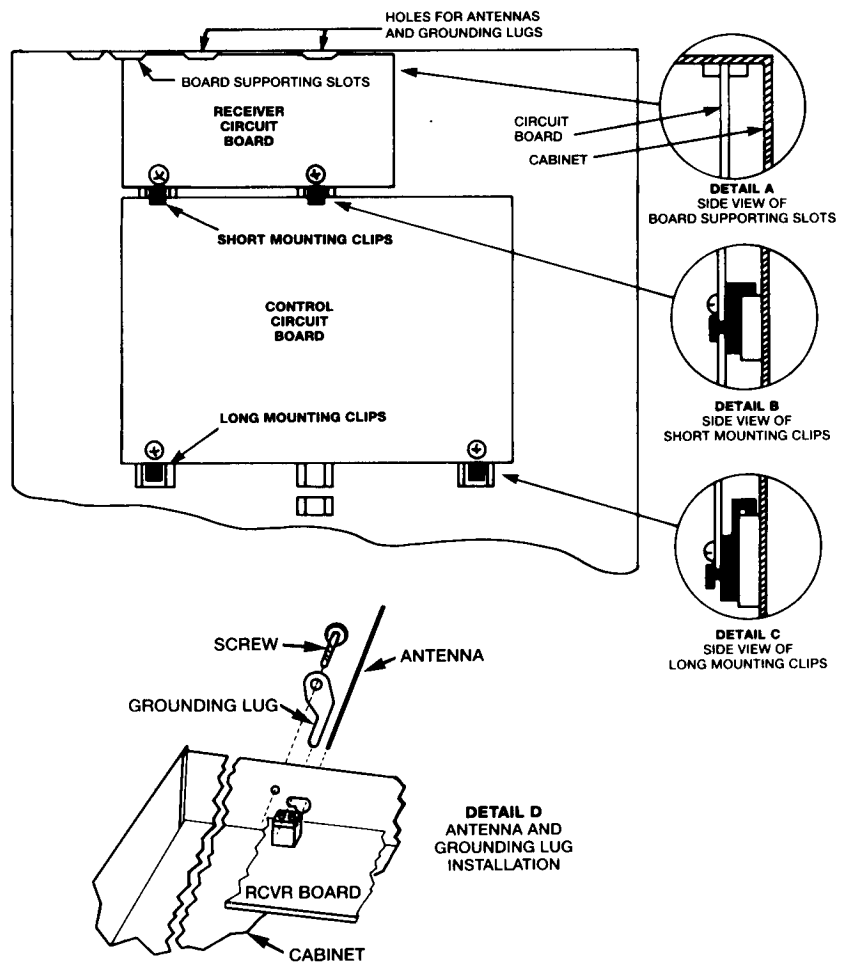

**Using Optional
Voice Module
or
Long Range Radio**

If used, an optional No. 4285 Voice Module may be installed inside the control cabinet (if space permits) or externally. Complete installation and connection information (to the control's console and telephone line connection points) accompanies the voice module.

Connection of the No. 7720ECP Long Range Radio (to the control's console connection points) is described in the information that accompanies the radio.

Section 4. WIRING & POWERING THE SYSTEM

(See Summary of Connections Diagram on Page 47)

IMPORTANT: Do not connect the battery, or plug in the AC transformer, until all other wiring connections have been completed.

Grounding the System

Terminal 21 is the earth ground connection point. In order for the protective devices in this product to be effective, the designated terminal must be terminated in a good earth ground. The following are examples of good earth grounds available at most installations:

Metal cold water pipe: Use a non-corrosive metal strap firmly secured to the pipe to which the lead is electrically connected and secured.

AC power outlet ground: Available from 3-prong, 120 VAC power outlets only. To test the integrity of the ground terminal, use a 3-wire circuit tester with neon lamp indicators, such as the UL Listed Ideal Model 61-035, or equivalent, available at most electrical supply stores.

Terminals and Connections

1 & 2: AC Input (16.5VAC, 25VA) from No. 1321/TF2 plug-in transformer (in U.S.A.).

Note: For Canadian installations, a No. 1321CN transformer must be used.

3: Alarm relay output(+), 12VDC, 2.0A maximum.
600mA max (Alarm plus Aux Power) for UL usage.

4: Ground (-) Return for Alarm Output, Auxiliary Power and Wired Fire. For Console(s)† and 4281/5881, and 5800TM, and/or 4219/4229/4204. Via BLACK leads.

5: +12VDC Output (at 500mA max.) for Auxiliary Power and Wired Fire. For Console(s)† and 4281/5881, and 5800TM, and/or 4219/4229/4204. Via RED leads.

6: Data In from Console(s)† and 4281/5881, and 5800TM, and/or 4219/4229/4204. Via GREEN leads.

7: Data Out to Console(s)† and 4281/5881, and 5800TM, and/or 4219/4229/4204. Via YELLOW leads.

8–13: *not used (Zones 1–4 not present)*

14: Zone 5. (When Zones 5 and/or 6 are used, a 1,000 Ohm EOLR should be wired between the farthest sensor connected to the zone terminal and the low side of the zone.)

15: Zones 5 and 6 Return.

16: Zone 6

17: Handset (TIP).

18: Handset (RING).

19: Incoming Phone Line (TIP).

20: Incoming Phone Line (RING).

21: EARTH GROUND (a proper earth ground must be provided to protect the system from lightning and electrostatic discharge damage).

Warning: To prevent the risk of electrical shock, disconnect the telephone line at the Telco jack before servicing the unit.

RED LEAD: Battery (+). When AC is present, 13.8VDC is being developed to recharge a gel lead acid battery and when AC is absent, 12VDC current is drawn from the battery. Battery lead reversal will blow the battery fuse.

BLACK LEAD: Battery (-).

† Up to 4 consoles may be used (check total auxiliary current, per *SPECIFICATIONS*). Consoles need not necessarily be on individual home runs, but no more than 220' of #22 wire or 550' of #18 wire should be used for each run.

Addressable consoles (e.g., 4137AD, 5137AD, 6128, 6137, 6138, and 6139) must be set to their non-addressable mode (device ID 31).

**OPTIONAL
4285 VOICE MODULE
and
7720ECP
LONG RANGE RADIO**

Use of these devices in conjunction with Console Connection terminals 4–7 and/or phone terminals 17–20 is described in the instructions that accompany those devices.

Power-up Procedure

1. Make sure that the total current to be drawn from the Alarm Output terminals (3 & 4) and Auxiliary Power Output terminals (4 & 5) does not exceed the values indicated in the *SPECIFICATIONS* section and on the *SUMMARY OF CONNECTIONS* diagram.
2. Wire the transformer to the panel (before connecting the battery) as shown on the *SUMMARY OF CONNECTIONS* diagram. **Do not plug in at this time.**
3. Connect all loops, devices, consoles, etc. to the panel.
4. Plug the transformer into a 24 hour, uninterrupted AC outlet. After some initial displays (see page 17) and approximately one minute, the green POWER or READY LED on the console(s) should be lit and the consoles should display "READY" (Fixed Word consoles) or "DISARMED READY TO ARM" (Alpha consoles).
5. Connect the battery as shown in the *SUMMARY OF CONNECTIONS* diagram.

Section 5. PROGRAMMING THE SYSTEM

General Information

Installer options are stored in non-removable, electrically erasable, non-volatile EEROM memory. These options must be programmed for the particular installation to establish its specific alarm and reporting features.

Note: It is possible to program the system at any time, even at the installer's premises prior to the actual installation. Simply apply power temporarily to the control and then program the unit as desired.

THE SECURITY CONTROL IS PROGRAMMED VIA A 5137AD OR 6139 ALPHA CONSOLE (or a download)

These consoles need not necessarily remain in the system after programming.

Note: These addressable consoles must be set to their non-addressable mode (device ID 31).

The initial sequence of entries should follow the order on the programming sheet.

*Certain programming fields, such as those used to select the expansion devices (fields *22 and *25) must be programmed before expansion zones can be programmed. If an expansion unit type is changed, the expansion zones should be reprogrammed.*

When programming, the field number will be displayed on the LCD display; also, each entry is displayed as it is keyed in. After programming, values that have been entered in each field can be reviewed and, if necessary, modified.

When programming from the console, note the following:

1. Enter the Programming mode by simultaneously depressing the [*] and [#] keys **within 50 seconds after power is applied to the Control**, or subsequently by keying the code 4 + 1 + 1 + 1 followed by depression of **CODE + 0** keys. If a different Master code is subsequently programmed, use it instead of 4111 to gain access to the Programming mode. *If the Programming mode was exited previously using a *98, it will prevent entry into the Programming mode by the use of the Master Code + CODE + 0.*
2. Immediately following entry into the program mode, field *20 will be displayed. Following the above display, the system is ready to accept entries for field *20.
3. To program a data field, key [*] plus **Field No.** (for example, *21), then make the required entry.

Some entries require sequential pressings of [*] to actually enter the data. This is true in the Zone and Relay fields *56, *80, and *81 and the prompts will indicate this. Entry of [#] will generally back up one entry position for review.

4. To simply review a data field, key [#] plus **Field No.**. Data will either be automatically sequentially displayed or can be displayed by successively pressing [#]. No changes will be accepted in this mode.
5. When a data field has been completely programmed, the console will normally "beep" three times and then automatically display the next data field number to be programmed (if not, key [*] plus the **Field No.** of the next field to be programmed).
6. If the number of digits that you enter in the data field is less than the maximum permitted (for example, phone number), then the console will display the last data entered. To proceed, the next data field number to be programmed must then be entered (for example, *42).
7. If a field is improperly entered, the console will display **EE**. Simply re-enter [*] or [#] plus the field number.

**Summary of
Programming
Commands**

FUNCTION	PROCEDURE
ENTER PROGRAMMING MODE	1. POWER UP, then depress [*] and [#] both at once, within 50sec of powering up. OR 2. Initially, key: 4 + 1 + 1 + 1 plus CODE key + 0. OR 3. If different Master Code is programmed, key : MASTER CODE + CODE KEY + 0. (if *98 was used to exit previously, method 1 above must be used to enter the program mode again)
INITIALIZE DOWNLOAD ID AND SUBSCRIBER ACCT NUMBER FOR DOWNLOADING	*96 No data entry required, loads defaults.
SET ALL PROGRAM FIELDS TO DEFAULT VALUES	*97 No data entry required.
EXIT PROGRAMMING MODE	*98 Inhibits re-entry to programming mode via type 2 or 3 entry method above. *99 Allows re-entry to programming mode via type 2 or 3 entry method.
ADVANCE TO FIELD	[*] + Field No. (e.g., 21, 38, 56, etc.)
PROGRAM FIELD	[*] + Field No., followed by data entries. Some fields require sequential pressings of [*] to enter data (e.g., fields 56, 80, 81).
ERASE FIELDS	[*] + Field No. + [*] (only applies to fields 40 thru 43 and 94).
READ FIELD	[#] + Field No. Data will either be automatically sequentially displayed or can be displayed by successively pressing [#].

Special Messages

OC = OPEN CIRCUIT (no communication between Console and Control).

EE = ERROR (program entry mistake). Re-enter the field number or data).

After powering up, **AC**, **dl** (disabled) or **System Busy** and **NOT READY** will be displayed after approximately 4 seconds. This will revert to **READY** in appx. 1 minute, which allows PIRS, etc. to stabilize. To bypass this delay, press: [#] + [0].

If **E4** or **E8** appears, more zones than the expansion units can handle have been programmed. Correct the programming and then completely de-power and re-power the control to clear this indication and remove the disable indication.

PROGRAMMING DATA FIELDS

THE CENTERFOLD PROGRAMMING FORM CAN BE USED TO RECORD THE DATA FOR THIS INSTALLATION

SYSTEM SETUP (*20-*27)

- *20 MASTER CODE**
Enter 4 digits, 0-9 (entry of all 4 is mandatory).
Use of a "9" in the last position inhibits the duress code feature.
- *21 QUICK ARM ENABLE**
If enabled, [#] key can be used instead of security code when arming.
Code is always required when disarming.
Enter 0 for disabled or 1 for enabled.
- *22 RF SYSTEM TYPE**
Select the RF system (receiver) type being used.
0 = none; 1 = 5700 (4281); 2 = 5800 (5881)
- *23 FORCED BYPASS FUNCTION**
All zones that are bypassed by this function will be displayed after the bypass is initiated.
0 = No forced bypass. 1 = Allows quick bypass of all open zones.
- *24 RF RECEIVER HOUSE ID CODE**
MUST enter for 5700 system's 4281 type receiver, or 5800 system's 5827 Wireless Keypad or 5827BD Bidirectional Console.
Enter 01-31 House ID.
- *25 WIRED EXPANSION/OUTPUT RELAY USED**
Select expansion/relay module being used.
0 = none; 1 = 4219; 2 = 4229; 3 = 4204
- *26 VOICE MODULE ACCESS CODE**
Supports the 4285 Voice Module on the console lines (the 4285 has a permanent device address of 4).
To enable, enter two digits. 1st digit: 1-9
2nd digit: '*' (enter #+11) or '#' (enter #+12)
To disable, enter 0 in either position.
- *27 OUTPUT TO LONG RANGE RADIO (e.g., No. 7720ECP)**
Enter 0 for no or 1 for yes.
If yes is selected, any dialer report programmed to report to the PRIMARY phone number (in field *47) will be sent, as well, via long range radio. All dialer and long range radio reports will be in Contact ID format (regardless of the selection made in field *46).
Note: The Radio should be programmed for a device address of 3 on the console lines.
Full Trouble and Restore messages are sent.

ZONE SOUNDS AND TIMING (*28-*39)

- *28 SINGLE ALARM SOUNDING PER ZONE (per armed period)**
Affects external sounder only, if yes is selected.
Enter 0 for no or 1 for yes.
- *29 FIRE SOUNDER TIMEOUT**
0 = Fire sounder times out at end of bell timeout period (field *30).
1 = Fire sounder continues until silenced manually.
- *30 ALARM BELL TIMEOUT**
External sounder will shut off after time allotted. Enter 1 digit.
0 = No timeout 1 = 4 minutes 2 = 8 minutes 3 = 12 minutes
- *38 ENTRY DELAY**
System will wait the time allotted before sounding alarm upon entering.
(EXIT delay = Entry delay plus 15 seconds)
0 = 0 sec, 1 = 20 sec, 2 = 30 sec, 3 = 45 sec, 4 = 60 sec, 5 = 90 sec.
- *39 AUDIBLE EXIT WARNING**
When arming AWAY or MAXIMUM, console sounds slow beeps during exit time, turning into fast beeps during last 5 seconds.
Enter 0 for no or 1 for yes.

**DIALER
PROGRAMMING
(*40-*50)**

In Fields *40, *41, *42:
Enter up to the number
of digits shown.
Do not fill unused spaces.
Enter 0-9,
#+11 for '*',
#+12 for '#',
#+13 for a pause

- *40 PABX ACCESS CODE (See box at left)**
Enter up to 4 digits if PABX code is needed to access an outside line. If fewer than 4 digits entered, exit by pressing * (and press 41 if entering next field). To clear entries from field, press *40*.
- *41 PRIMARY PHONE No. (See box at left)**
Enter up to 12 digits. If fewer than 12 digits entered, exit by pressing * (and press 42 if entering next field). To clear entries from field, press *41*.
Note: Back-up reporting (8 calls are made to the secondary phone number if no kiss-off is received after 8 attempts to the primary number) is automatic only if there is a secondary phone number.
- *42 SECONDARY PHONE No. (See box at left)**
Enter up to 12 digits. If fewer than 12 digits entered, exit by pressing * (and press 43 if entering next field). To clear entries from field, press *42*. See Note in field above.
- *43 SUBSCRIBER ACCOUNT No.**
Enter digits 0-9, #+11=B, #+12=C, #+13=D, #+14=E, or #+15=F. Enter * as the fourth digit if a 3 digit acct no. (for 3+1 dialer reporting format) is used. Enter 0 as the first digit of a 4-digit acct no. for nos. 0000-0999. End field by pressing * (and press next field) if only 3 digits are used. To clear entries from field, press *43*.
- *45 PHONE SYSTEM SELECT**
Enter 1 digit.
If Central Station Rcvr *is not* on WATS line:
0 = Pulse Dial 1 = Tone Dial
If Central Station Rcvr *is* on WATS line:
2 = Pulse Dial 3 = Tone Dial
- *46 REPORT FORMAT**
Determine format to be used to report to the central station. Enter 1 digit.
0 = 3+1; 4+1 ADEMCO Low Speed Std. 6 = 4+2 ADEMCO Express
1 = 3+1; 4+1 Radionics Standard 7 = ADEMCO Contact ID Reporting
2 = 4+2 ADEMCO Low Speed Standard 8 = 3+1; 4+1 ADEMCO Low Speed Expanded
3 = 4+2 Radionics Standard 9 = 3+1; 4+1 Radionics Expanded
(Enter * as the 4th digit of *43, if 3+1 dialer reporting is to be used.)

For explanation of these formats, see page 30.

Notes: The maximum number of alarm and alarm restore reports during one armed period is determined by field *92.
See field *27, which may override this field's selection.
- *47 SPLIT/DUAL REPORTING**
Enter 0 to disable (Backup report only). To enable, enter 1-5.

TO PRIMARY PHONE No.	TO SECONDARY PHONE No.
1 = Alarms, Restore, Cancel	Other Reports
2 = All Reports except Open/Close, Test	Open/Close, Test
3 = Alarms, Restore, Cancel	All Reports
4 = All Reports except Open/Close, Test	All Reports
5 = All Reports	All Reports
- *48 15 SECOND DIALER DELAY (BURGLARY)**
Allows time for subscriber to avoid a false alarm transmission.
Enter 0 for no or 1 for yes.
- *49 PERIODIC TEST MESSAGE**
Select the desired test report interval.
0 = none; 1 = 24 hours; 2 = weekly; 3 = monthly
Test Report Code entered in field *64 is sent.
- *50 SESCOA/RADIONICS SELECT**
0 = Radionics (0-9, B-F reporting) 1 = SESCOA (0-9 only reporting)
- *51 CONFIRMATION OF ARMING DING**
Enter 0 for no or 1 for yes.
If selected, ding is external sounder only and will occur at time of kiss-off of closing report. If closing report is not programmed, ding will occur at end of exit time.

**ARMING DING
(*51)**

**ZONE ASSIGNMENT/
ALARM REPORT
CODES, etc.
(*56)**

***56 ZONE ASSIGNMENT/ALARM REPORT CODES
(and RF Input ID Learning for 5800 System)
REFER TO THE ZONE ASSIGNMENT TABLE FOR THIS FIELD
ON THE CENTERFOLD PROGRAMMING FORM**

Enter Zn Num.
(00=Quit) 20

Zone 20 entered ↑

Zn ZT – RC In: L
20 09 – 10 RF: -

↓ Zone Number

20 Zone Type
Perimeter 03

Zone Type ↑

This field is used to program zone numbers, zone types, alarm and report codes, and to identify the type of loop input device. This field can also be used for "learning" 5800 series transmitter ID codes and for entering alpha descriptors for zones.

Zone Number (Zn): Upon entering field *56, enter the zone number that you wish to program (or [0][0] to leave zone programming).

Press [*]. A summary display will come up, showing the status of that zone's program.

If it is programmed satisfactorily, press [#] to back up one step and enter another zone number, if desired.

If the zone is not programmed, or you want to change it, press [*]. A prompt for Zone Type will appear.

Zone Type (ZT): Each zone must be assigned to a zone type, which defines the way in which the system responds to faults in that zone.

Enter the zone type code (or change it, if necessary). Zone types are defined below.

ZONE RESPONSE TYPE DEFINITIONS

Zone Type 02 is not used in this system.

Type 00

Zone Not Used

Program a zone with this zone type if the zone is not used.

Type 01

Entry/Exit Burglary

This zone type provides entry delay whenever the zone is faulted if the control is armed in the Away or Stay modes. When the panel is armed in the Instant or Maximum modes, no entry delay is provided. Exit delay begins whenever the control is armed, regardless of the arming mode selected. These delays are programmable. This zone type is usually assigned to sensors or contacts on doors through which primary entry and exit will take place.

Type 03

Perimeter Burglary

This zone type gives an instant alarm if the zone is faulted when the panel is armed in the Away, Stay, Instant or Maximum modes. This zone type is usually assigned to all sensors or contacts on exterior doors and windows.

Type 04

Interior, Follower

This zone type is active when the panel is armed in the Away or Maximum modes. Entry delay (using the programmed entry time) results if the panel is armed in the Away mode and the entry/exit zone is faulted first. Otherwise this zone type gives an instant alarm. *Exit* delay is present for *any* arming mode. This zone type is usually assigned to a zone covering an area such as a foyer, lobby, or hallway through which one must pass (upon entry, after faulting the entry/exit zone) to reach the console to disarm the system. Since this zone type is designed to provide an instant alarm if the entry/exit zone is not violated first, it will protect an area in the event an intruder hides on the premises prior to the system being armed, or gains access to the premises through an unprotected area. **This zone type is bypassed automatically when the panel is armed Stay or Instant.**

Type 05

**Trouble by Day/
Alarm by Night**

This zone type will give an instant alarm if faulted when armed in the Away, Stay, Instant or Maximum (night) modes. During the disarmed state (day), the system will provide a latched trouble sounding from the console (and a central station report, if desired). This zone type is usually assigned to a zone which contains a foil-protected door or window (such as in a store), or to a zone covering a "sensitive" area such as a stock room, drug supply room, etc. This zone type can also be used on a sensor or contact in an area where immediate notification of an entry is desired.

Type 06
24-hour Silent Alarm

This zone type sends a report to the Central Station but provides no console display or sounding. This zone type is usually assigned to a zone containing an Emergency button.

Type 07
24-hour Audible Alarm

This zone type sends a report to the Central Station, and provides a rapid beeping sound at the console, and an audible external alarm. This zone type is usually assigned to a zone that has an Emergency button.

Type 08
24-hour Auxiliary Alarm

This zone type sends a report to Central Station and provides a rapid beeping sound at the console. **(No bell output is provided).** This zone type is usually assigned to a zone containing a button for use in personal emergencies, or to a zone containing monitoring devices such as water or temperature sensors, etc.

Type 09
Supervised Fire

This zone type provides a fire alarm on short circuit and a trouble condition on open circuit. The bell output will pulse when this zone type is faulted. This zone type is always active and cannot be bypassed. This zone type can be assigned to control panel wired zone 5, any zone in a wired zone expansion module, or certain wireless zones.

Type 10
Interior w/Delay

This zone type gives *entry* delay (using the programmed entry time), if tripped when the panel is armed in the Away mode, regardless of whether or not an entry/exit delay zone was tripped first. This zone type is also active during Maximum mode, but *no* entry delay is provided (an alarm occurs immediately if the zone is tripped). *Exit* delay is present for *any* arming mode. **This zone type is bypassed automatically when the panel is armed Stay or Instant .**

Type 20
Arm-Stay

This is a special purpose zone type used with 5800 series wireless pushbutton or contact closure or opening, and which will result in arming the system in the STAY mode when the zone is activated.

Type 21
Arm-Away

This is a special purpose zone type used with 5800 series wireless pushbutton or contact closure or opening, and which will result in arming the system in the AWAY mode when the zone is activated.

Type 22
Disarm

This is a special purpose zone type used with 5800 series wireless pushbutton or contact closure or opening, and which will result in disarming the system when the zone is activated.

Type 23
No Alarm Response

This zone type can be used on a zone when an output relay action is desired, but with no accompanying alarm (ex. lobby door access).

By using a 4281/5881 RF Receiver and the appropriate 5700/5800 series transmitters, all of the above zone types are available for the wireless portion of the system.

20 Report Code
1st 00 2nd 00 00

When the display shows the zone type you want, press [*] to advance to...

Report Code (RC): The report code consists of 2 hexadecimal digits, each in turn consisting of 2 numerical digits. For example, for a report code of "3C", enter [0][3] for "3" and [1][2] for "C". Enter the numbers and press [*] to advance to...

20 Input Device
RF Trans. RF:

Input Device (In): For the hard wired zones of the **Ademco via30+** (HW), the auxiliary wired expansion zones on a 4219 or 4229 (AW), and the zones for a 5700 system's transmitters (RF), the Input Device types are automatically assigned (Panic, Duress, and Tamper inputs are not applicable).

For a 5800 system's transmitters, "RF" is initially displayed, but should be changed to "UR" (Unsupervised RF, enter 4) for units that can be carried off-premises (e.g., No. 5801), or to "BR" (Button type RF, enter 5) for small transmitters that cannot be supervised (e.g., Nos. 5802, 5802CP, 5803). Check the instructions that come with the transmitter for the proper input. When all is okay, press [*] to advance to...

20 Learn S/N ?
0=No 1=Yes 0

TRANSMIT NOW

TYPICAL DISPLAY
Zn ZT – RC In: L
20 03 – 3C RF: 2

Accepted Input (Loop) Number ↑

Program Alpha?
0=No 1=Yes 0

Learning RF Input (L): Applicable to a 5800 system only.

Note: Where a "Yes–No" is asked by the console, pressing the [*] or [0] for No is equivalent.

This request will be to learn the transmitter input's ID code. (The ID codes can be learned here or via field *83.)

If "yes" is selected, open and close (or close and open), or press and release the particular input to the transmitter twice. After the first time, a single short beep will occur. After the second time, two short beeps will mean that the control has accepted that transmitter into the system. Because of the characteristics of the receiver, allow about 8 seconds between transmissions from button units (e.g., 5802, 5802CP, 5803). If a long beep occurs, it means that the particular transmitter input has previously been registered in the system.

The display will revert to the summary line, with the accepted input (loop) number under the "L" in the display.

Mark the zone number on the transmitter.

If all is okay, press [*].

Custom Alpha Editing: For all zone types, the next request is to enter alpha descriptors for the zones. The entry may be done now (enter 1) or may be done at a later time via field *82 (enter 0).

See the ALPHA DESCRIPTION ENTRIES section on page 29.

Enter Zn Num.
(00=Quit) 00

When all entries to be made for the zone at this time are complete, the next zone number can be entered for programming, or zone programming can be ended by entering [0][0] as the next "zone number".

Notes:

- *When using a 5801, the Input (Loop) "4" button should always be used and learned by the system.*
- *In field *56, at the summary line for each zone, the entered values can be checked. If it is desired to change anything, press [#] to move to the previous entry. Press [#] a number of times to move to earlier entries. Press [*] to move to later entries again.*
- *Zone entries can be reviewed by pressing [#][5][6]. Changes cannot be made here, so this is safer for review. Enter the first zone number to be viewed and press [#]. To view each zone, press [#] and the zone number will advance to the next programmed zone. When the end of the list is reached, press [0][0] to exit. This method of exiting may also be done at any time during the review.*
- *To either temporarily or permanently remove a zone from the system, go into programming mode and press [*][5][6]. Enter the zone number and press [*]. At the Zone Type prompt, enter [0][0] and [*]. This sets the type of the zone to Not Used. The next prompt will be "Delete Zone?". "Yes" will permanently remove the zone from the system while "No" will disable it but retain all data except the original zone type. You can then go back to this zone later and put back an active Zone Type to re-enable it.*
- *An ID code that has been learned for a 5800 system will not be deleted if the zone is disabled as described above. If only the physical transmitter is to be removed or changed (i.e., its ID code deleted, as when replacing a unit that has a non-removable battery), it can be done in field *56 or *83. In programming mode, press [*][5][6], enter the zone number, and press [*] multiple times until the cursor is under the Learned RF Input (L) position. This is the specific input (loop) or button on the transmitter that has been learned for that zone. If a [0] is entered at this point, a prompt "Delete S/N?" will appear. If "Yes" is entered, this specific ID code will be deleted from the system.*

20 Zone Type
Not Used 00

20 Delete Zone?
1=Yes 0=No

**TO PROGRAM SYSTEM
STATUS & RESTORE
REPORT CODES
(*60-*75)**

With a 3+1 or 4+1 Standard Format: Enter a code in the *first digit* box: 1-9, 0, B, C, D, E, or F. Enter "#+10" for 0, "#+11" for B, "#+12" for C, "#+13" for D, "#+14" for E, "#+15" for F.

A "0" (*not* "#+10") in the *first digit* box will disable a report.

A "0" (*not* "#+10") in the *second digit* box (if any) will result in automatic advance to the next field when programming.

With an Expanded or 4+2 Format: Enter codes in *both* boxes (1st and 2nd digits) for 1-9, 0, or B-F, as described above.

A "0" (*not* "#+10") in the *second* box will eliminate the expanded message for that report.

A "0" (*not* "#+10") in *both* boxes will disable the report.

With Ademco Contact ID Reporting: Enter any digit (other than "0") in the *first* box, to enable zone to report. This is an "enabling" code only and is disregarded in the actual reporting to the central office. Entries in the *second* boxes will be ignored.

A "0" (*not* "#+10") in the *first* box will disable the report.

See *Examples* on programming form.

**SYSTEM STATUS
REPORT CODES
(*60-*68)**

*60 TROUBLE REPORT CODE (See box above.)

*61 BYPASS REPORT CODE (See box above.)

*62 AC LOSS REPORT CODE (See box above.)

*63 LOW BAT REPORT CODE (See box above.)

*64 TEST REPORT CODE (See box above.)

*65 OPEN/EXIT ALARM REPORT CODE, 1st DIGITS

Open Report Code : To enable, enter a code (or 0 to disable) in the left-hand box (see box above *60).

For expanded or 4+2 reporting, 2nd digit = User #.

Exit Alarm Report Code: To enable, enter a code (or 0 to disable) in the right-hand box (see box above *60). If enabled:

ANY ALARM FROM AN EXIT OR INTERIOR ZONE OCCURRING WITHIN TWO MINUTES AFTER THE END OF THE EXIT DELAY will send a special message indicating exit alarm to the central station, and a zone indication and "Exit Alarm" or "EA" is displayed on the console.

IF AN EXIT OR INTERIOR ZONE CONTAINS A FAULT AS THE EXIT DELAY ENDS, the local bell and console sound continuously.

a) *If the subscriber then disarms the system before the ensuing ENTRY delay ends,* no message is transmitted to the central station, but a zone indication and "Canceled Alarm" or "CA" is displayed on the console.

b) *If the system is not disarmed before that entry delay ends,* a special message indicating Exit Alarm is sent to the central station and a zone indication and "Exit Alarm" or "EA" is displayed on the console.

For expanded or 4+2 reporting, a 2nd digit is sent, and is the same as the 2nd digit of the zone alarm report code programmed in field *56.

For Contact ID reporting, Event code 374 and the zone number is sent.

There is no restore message for Exit Alarm report.

*66 AWAY/STAY CLOSE RPT CODE, 1st DIGITS (See box above.)

To enable, enter a code (or 0 to disable) in either or both boxes

For expanded or 4+2 reporting, 2nd digit for each = User # .

*67 RF XMTR. LOW BATTERY REPORT CODE (See box above.)

*68 CANCEL REPORT CODE (See box above.)

**RESTORE
REPORT CODES
(*69-*75)**

*69 GROUP RESTORES FOR TROUBLE, RF LOW BAT, BYPASS

Enter: 0 for no (report for each restore),

or: 1 for yes (report after all zones restored).

Note: "1" not applicable to Contact ID reporting.

*70 ALARM RESTORE REPORT CODE, 1ST DIGIT

For expanded or 4+2 reporting, a 2nd digit is sent, and is the same as the 2nd digit of the zone alarm report code programmed in field *56.

*71 TROUBLE RESTORE REPORT CODE (See box above.)

*72 BYPASS RESTORE REPORT CODE (See box above.)

*73 AC RESTORE REPORT CODE (See box above.)

*74 LOW BAT RESTORE REPORT CODE (See box above.)

*75 RF XMTR. LOW BATTERY RESTORE CODE (See box above.)

***80 OUTPUT RELAYS**

*Applicable only if field *25 is programmed for a 4229 or 4204...otherwise skip this field.*

**REFER TO THE OUTPUT RELAY TABLE FOR THIS FIELD
IN THE PROGRAMMING FORM.**

Relay Basics

Relays can be used to perform many different functions and actions. In this system, each relay must be programmed as to how to act (ACTION), when to activate (START), and when to deactivate (STOP). Each of these is summarized briefly below, but described later in detail in the programming procedure for fields *80 and *81.

1. **ACTION:** The "ACTION" of the relay is how the relay will respond when it is activated by the "START" programming. There are 4 different choices of actions:
 - CLOSE for 2 SECONDS and then reset.
 - CLOSE and STAY CLOSED until deactivated by "STOP" programming.
 - PULSE ON and OFF until deactivated by "STOP" programming.
 - NO RESPONSE is chosen when the relay is not used.
2. **START:** The "START" programming instructs the relay when and under what conditions to activate. There are 3 parts to be programmed:
 - EVENT instructs the relay what condition must occur to the zone(s) programmed into the "ZONE LIST" in order to activate the relay. The "EVENT" and "ZONE LIST" work together. The 4 different choices for "EVENT" are listed in the *PROGRAMMING* section for field *80.
 - ZONE LIST is a list of zones selected by the installer in field *81. When an event occurs as assigned by "EVENT" on any zone within that list, the relay will activate as selected in "ACTION". In this way, many zones can be assigned very easily to a single event. **For example:** *You may wish a relay to activate (perhaps to activate a strobe for a visual indication) whenever any zone in a group of zones is faulted.*
 - ZONE TYPE/SYSTEM OPERATION. Instead of using a "ZONE LIST" and "EVENT", a specific zone (response) type or system operation action can be selected to activate the relay.
 - If a specific "ZONE TYPE" is chosen**, any zone of that response type going into alarm, trouble, or fault will cause the relay to activate as selected in "ACTION".
 - If a "SYSTEM OPERATION" is chosen**, that operation will cause the relay to activate as selected in "ACTION".The different choices for "ZONE TYPE" and "SYSTEM OPERATION" are listed in the *PROGRAMMING* section for field *80.
3. **STOP:** The "STOP" programming instructs the relay when and under what conditions to deactivate. The 2 parts to be programmed are:
 - RESTORE ZONE LIST. If a "RESTORE ZONE LIST" is used, the relay will deactivate when all the zones in that list restore from a previous fault of alarm condition. This will occur regardless of what is programmed to "START" the relay; therefore, a "RESTORE ZONE LIST" would normally only be used when a "ZONE LIST" is used to start the relay.
 - ZONE TYPE/SYSTEM OPERATION. Instead of using a "RESTORE ZONE LIST", a specific zone (response) type or system operation action can be selected to deactivate the relay.
 - If a specific "ZONE TYPE" is chosen**, any zone of that response type that restores from a previous alarm, trouble, or fault condition will cause the relay to deactivate.
 - If a "SYSTEM OPERATION" is chosen**, that operation will cause the relay to deactivate.The different choices for "ZONE TYPE" and "SYSTEM OPERATION" are listed in the *PROGRAMMING* section for field *80.

Output Relay Displays



Enter Relay No.
(00 = Quit) 01

Upon entering field *80, this screen will appear. Enter the Relay Number 01 or 02 for a 4229, or 01, 02, 03, or 04 for a 4204 (or 00 to end these entries). Press the [*] key to advance.

The data is keyed in and entered for this and the following screens by pressing []. To back up to check an entry, press [#] for each position. Press [*] to go forward again.*

Relay being programmed.

02 A EV ZL ZT
STT 0 0 0 00

This screen displays a summary of the current relay START programming (for this example, relay 02 has been selected). Press the [*] key to advance.

02 A EV ZL ZT
STP - - 0 00

This screen displays a summary of the current relay STOP programming. Press the [*] key to advance.

02 Relay Action
No Response 0

Action (A): Enter the desired relay action. Press the [*] key to advance.

0 = Not Used 2 = Close and Stay Closed
1 = Close for 2 seconds 3 = Continual Pulses (1 sec) On and Off

02 Start Event
Not Used 0

Event (EV): Enter the event to START the relay. Press the [*] key to advance.

0 = Not used 2 = Fault
1 = Alarm 3 = Trouble

02 Start: Zn List
No List 0

Zone List (ZL): If a zone list will be used to START the relay action, enter the zone list number (to be programmed in field *81): 1, 2, or 3. If not used, enter 0. Press the [*] key to advance.

02 Start: Zn Typ
Zone Disabled 00

Zone Type/System Operation (ZT): If a zone type or system operation will be used to START the relay action, enter the appropriate two digit code. If not, enter 00. Press the [*] key to advance.

CHOICES FOR ZONE TYPES

00 = Not Used 05 = Trouble Day/Alarm Night 08 = 24 Hr Aux
01 = Entry/Exit 06 = 24 Hr Silent 09 = Fire
03 = Perimeter 07 = 24 Hr Audible 10 = Interior w/Delay
04 = Interior Follower

CHOICES FOR SYSTEM OPERATION

20 = Arming-Stay 33 = Any Burglary Alarm 38 = Chime
21 = Arming-Away 34 = Code + # + 7 Key Entry 39 = Any Fire Alarm
22 = Disarming (Code + OFF) 35 = Code + # + 8 Key Entry 40 = Bypassing
31 = End of Exit Time 36 = At Bell Timeout** 41 = AC Power Failure
32 = Start of Entry Time 37 = 2 times Bell Timeout** 42 = System Battery Low

**Or at Disarming, whichever occurs earlier.

02 Stop: Zn List
No List 0

"Restore of" Zone List (ZL): If a zone list will be used to STOP the relay action, enter the zone list number (to be programmed in field *81): 1, 2, or 3. If not used, enter 0. Press the [*] key to advance.

02 Stop: Zn Typ
Zone Disabled 00

Zone Type/System Operation (ZT): If a zone type or system operation will be used to STOP the relay action, enter the appropriate two digit code (see the "ZT" choices listed above). If not, enter 00. Press the [*] key to advance.

02 A EV ZL ZT
STT 0 0 0 00

This screen again displays a summary of the current relay START programming. Press the [*] key to advance.

02 A EV ZL ZT
STP - - 0 00

This screen again displays a summary of the current relay STOP programming. Press the [*] key to return again to the first screen so that the next relay number to be programmed can be entered, or enter [0][0] to end relay programming.

Note: *Previously entered data can be reviewed by pressing [#] [8] [0]. After the relay number is chosen, press [#] to go to the next screens. This is a review mode only, and data cannot be changed.*

**Example of
Output Relay
Programming**

**FOR OTHER EXAMPLES
SEE THE TABLE
ON PAGE 44**

Let us light an indicator when any one of 3 specific zones are faulted or when any 24 hour aux. zone is disturbed. We want to turn off the indicator manually without affecting the arming status of the system.

In field *80 we choose Output Relay 01 and program the Action (A) to be "2" (Close and stay closed). The Event we are looking for to start the relay action is a fault, so we will program "2" in (EV). We will use Zone List 1 for the 3 specific zones, so will program "1" in (ZL), (and will program these 3 zones in field *81's Zone List 1).

The second condition for turning on the indicator is triggering a 24 hour aux. zone (Zone Type 08), so we will program (ZT) as "08".

To stop relay action and turn off the indicator, we do not want to use a restore of any zone, so we will program a "0" for the "Restore of" Zone List (ZL). To choose a manual entry of User Code + [#] + [7] to turn it off, we will program (ZT) as "34".

If no other relay is to be programmed we go to field *81 and program the 3 specific zones in Zone List 1.

Zone List Displays



Zone List No.
(00 = Quit) 01

↓ Zone List selected.

03 Enter Zn Num.
(00 = Quit) 00

03 Del Zn List?
0 = No 1 = Yes 0

03 Delete Zone?
0 = No 1 = Yes 0

03 Zn to Delete?
(00 = Quit) 00

*** 81 ZONE LISTS FOR OUTPUT RELAYS**

*Applicable only if field *25 is programmed for a 4229 or 4204...otherwise skip this field.*

Upon entering field *81, this screen will appear. Enter the Zone List Number 01, 02, or 03 to program (or 00 to end these entries). Press the [*] key to advance. In the following displays, zone list 03 has been selected for programming.

Enter each zone number to add to the zone list by first entering the zone number, then the [*] key (ex., 01*, 02*, 03*). After all desired zones are entered, enter 00 to advance.

To delete the zone list, enter 1 (Yes). All zones in the zone list will be deleted automatically and programming will return to the first screen. To save the zone list, enter 0 (No) to advance.

To save the entire zone list, enter 0 (No) and programming will return to the first screen.

To delete a zone or zones in a zone list enter 1 (Yes) to advance.

Enter each zone to be deleted from the list, followed by the [*] key. After all zones to be deleted are entered, enter 00 to return to the first screen so that another list can be programmed, if desired. .

- Notes:**
- Any list may include any or all of the system's zone numbers.
 - A zone list can be assigned to more than one output relay.
 - If you only want to review what has been programmed previously, enter [#][8][1]. The review can be advanced by using the [#] key. When finished, enter [0][0] to quit. No programmed values can be disturbed in this mode.

*** 82 CUSTOM ALPHA EDITING (Also entered from field *56)**

See ALPHA DESCRIPTION ENTRIES section on page 29.

*** 83 ADD/DELETE 5800 RF INPUT IDs (Serial Nos & Sensor Pts)**

See procedure in last paragraph of field *56.

*** 92 MAXIMUM NUMBER OF REPORTS PER ARMED PERIOD**

Enter: 0 for a maximum of 10 total alarm plus alarm restore reports,
or: 1 for an unlimited number.

*** 94 DOWNLOAD PHONE NUMBER**

Enter up to 12 digits, 0-9, #+11 for '*', #+12 for '#', #+13 for a pause. Do not fill unused spaces. If fewer than 12 digits entered, end field by entering * (and press next field number). To clear field, press *94*.

*** 95 RING DETECTION COUNT FOR DOWNLOADING**

Enter number of rings before control picks up phone line (or 0 or 15).

- 0 = disable station initiated download
- 1-14 = # of rings
- 15 = answering machine defeat

**DOWNLOAD
INFORMATION
(*94, *95)**

- *96 INITIALIZE DOWNLOAD ID AND SUBSCRIBER ACCT. No. FOR DOWNLOADING
(No data entry required, loads defaults)
- *97 SET ALL PROGRAM FIELDS TO DEFAULT VALUES
(No data entry required)

Press *98 or *99 if exiting programming, or next Field No. if continuing.

**TO EXIT
PROGRAMMING MODE
(*98 or *99)**

- *98 EXITS PROGRAMMING MODE and prevents re-entry by :
Master Code + CODE + 0
- *99 EXITS PROGRAMMING MODE and allows re-entry by:
Master Code + CODE + 0
or by:
Power-up + * + #.

ALPHA DESCRIPTION ENTRIES

See the ALPHA FIXED DICTIONARY and CHARACTER CHART on page 29. If using a 4285 Voice Module, selection from the group of words in **boldface type** is suggested. *The voice module will not provide annunciation of the other words.*

**Assigning
Zone Descriptors**

The Alpha Console used with the *Ademco via30+* can have a user-friendly English language description/location of all protection zones, keypad panics, and RF receiver supervision faults programmed into the system. Each description can be composed of a combination of words (up to a maximum of 3) selected from a vocabulary of 244 words stored in memory (see page 29). In addition, up to 5 installer-defined words can be added to those already in memory. Thus, when an alarm or trouble occurs in a zone, an appropriate description for that zone's location will be displayed at the console.

Note: Alpha Descriptor entry can be done locally at the Alpha Console or remotely using a 4130PC Downloader. The Alpha Console procedure is described below.

**Entering
Zone Descriptors
(in field *56 or *82)**

1. The descriptor can be entered when the zone is being defined in field *56 or it can be entered later, in field *82.
2. Key [*][0][1] to begin entering the description for zone 1 (key [*][0][2] for zone 2, [*][0][3] for zone 3, etc.). *If nothing was entered previously*, the following will be displayed: * ZN 01 A

Note that the first letter of the alphabet appears after the zone number, and that the zone number is automatically included with the description. *If there already is a description for the zone*, the description will appear (with no cursor, since this is a display mode). *If it is desired to enter or change a description*, key in [*] + Zone Number again. A flashing cursor will now appear.

3. **One of two methods of entering the words can now be used** (assume, for example that the desired description for zone 1 is *BACK DOOR*):
 - a) Press [#] followed by the 3 digit number of the first word from the fixed dictionary shown on page 29 (e.g., [0][1][3] for *BACK*). Press [6] in order to save the word and proceed, or...

- IN STEPS 3-5,
THE CONSOLE KEYS
PERFORM
THE FOLLOWING FUNCTIONS**
- [3] Advances through alphabet and actual words in alphabetical order.
 - [1] Moves backward through alphabet and actual words in alphabetical order.
 - [6] Toggles between alphabet and actual word list; used to accept entries.
 - [8] Saves the zone description in the system's memory.

**Adding Custom Words
(will not be annunciated
by 4285 Voice Module)**

- IN STEPS 3-6,
THE CONSOLE KEYS
PERFORM
THE FOLLOWING FUNCTIONS**
- [3] Advances through alphabet, symbols, and numbers.
 - [1] Moves backward through alphabet, numbers and symbols.
 - [6] Selects desired letter; moves cursor one space to right.
 - [4] Moves cursor one space to left.
 - [7] Inserts a space at the cursor location, erasing any character located there.
 - [8] Saves the new word in the system's memory.

- b) **Select the first letter of the desired description** (note that "A" is already displayed). Press key [3] repeatedly to advance through the alphabet (e.g., to "B"), or key [1] to go backward. Then press [6] to display the first available word beginning with the desired letter (e.g., BABY). Next, press [3] repeatedly to move forward, or [1] to move backward, until the desired word is displayed (e.g., BACK). Then press [6] to accept the word and toggle back to the alphabet list.
4. For selection of the next word (e.g., DOOR), repeat steps 3a or 3b. For 3b, press key [3] until the first letter of the next word appears (e.g., "D"). Then press [6] to display the first available word beginning with that letter (e.g. DAUGHTERS). Press [3] repeatedly until the desired word (e.g., DOOR) appears. To accept the word, press [6], which toggles back to the alphabet list.
 5. When all desired words have been entered, press [8] to store the description in memory.
 6. *In field *56*, the next zone number in sequence will now be displayed for *complete* zone information entry.
*In field *82*, enter [*][N][N], where NN is the next zone that you want to review or for which you want to program a descriptor. To modify the descriptor, enter [*][N][N] again. To exit this mode, press [*][0][0].

Up to five installer-defined words can be added to the built-in vocabulary. Each of the five "words" can actually consist of a "word string" of *several* words, but no more than *ten* characters can be used for each word or word string.

1. Select CUSTOM WORD mode when the question arises.
2. Key the number ([1]–[5]) of the custom word or word string to be created (for example, if you are creating the *first* custom word or word-string, enter [1], for the *second*, enter [2], etc.). A cursor will now appear at the beginning of the second line.
3. **One of two methods of entering the custom word's characters can now be used** (refer to the *CHARACTER LIST* of letters, numbers, and symbols on the next page):

Important: Custom words must begin with an *alphabetic* character. If a number or symbol is used as the first character, the word will not be saved.

 - a) **Press the [#] key, followed by the two digit entry for the first letter you would like to display** (e.g., [6][5] for "A"), or...
 - b) **Use the [3] key to advance through the list of symbols, numbers, and letters.** Use the [1] key to move back through the list.
4. When you have reached the desired character, press [6] to select it. The cursor will then move to the right, in position for the next character.
5. Repeat steps 3 and 4 to create the desired word(s). Note that the [4] key can be used to move the cursor to the left, if necessary, and that key [7] can be used to enter a blank (or erase an existing character). Remember, no word or word-string can exceed 10 characters.
6. Press the [8] key to save the custom word(s) and return to the "CUSTOM ?" display. Repeat steps 2-5 for other custom words to be entered. To change a custom word, just overwrite it. If no more are to be entered now, press [0] to return to the Descriptor entry. The custom word(s) will be automatically added to the built-in vocabulary.

When zone descriptors are being entered as described in step 3a of the *Entering Zone Descriptors* section, the custom word numbers are 250 to 254 for words 1 to 5 respectively. When being entered as described in step 3b of that section, each word will be found at the end of the group of words that begin with the same letter as it does.

ALPHA FIXED DICTIONARY

(For Entering Zone Descriptors)

000 (Word Space)	054 DISCRIMINATOR	105 KITCHEN	155 RADIO	209 VALVE
• 001 AIR	055 DISPLAY	• 106 LAUNDRY	• 156 REAR	210 VAULT
• 002 ALARM	056 DOCK	• 107 LEFT	157 RECREATION	211 VIBRATION
003 ALCOVE	• 057 DOOR	• 108 LEVEL	158 REFRIG	212 VOLTAGE
004 ALLEY	058 DORMER	• 109 LIBRARY	159 REFRIGERATION	
005 AMBUSH	• 059 DOWN	• 110 LIGHT	160 FF	213 WALL
• 006 AREA	• 060 DOWNSTAIRS	• 111 LINE	• 161 RIGHT	214 WAREHOUSE
• 007 APARTMENT	061 DRAWER	• 112 LIQUOR	• 162 ROOM	215 WASH
008 ART	• 062 DRIVEWAY	• 113 LIVING	163 ROOF	• 216 WEST
• 009 ATTIC	063 DRUG	• 114 LOADING		• 217 WINDOW
010 AUDIO	• 064 DUCT	115 LOCK	164 SAFE	218 WINE
011 AUXILIARY		116 LOOP	165 SCREEN	• 219 WING
	• 065 EAST	117 LOW	166 SENSOR	220 WIRELESS
• 012 BABY	066 ELECTRIC	• 118 LOWER	• 167 SERVICE	221 WORK
• 013 BACK	067 EMERGENCY		• 168 SHED	
• 014 BAR	068 ENTRY	• 119 MACHINE	169 SHOCK	222 XMITTER
015 BARN	• 069 EQUIPMENT	120 MAGNETIC	• 170 SHOP	
• 016 BASEMENT	070 EXECUTIVE	121 MAIDS	171 SHORT	223 YARD
• 017 BATHROOM	• 071 EXIT	122 MAIN	• 172 SHOW	
• 018 BED	072 EXTERIOR	• 123 MASTER	• 173 SIDE	224 ZONE (No.)
• 019 BEDROOM		124 MAT	174 SKYLIGHT	• 225 ZONE
020 BELL	• 073 FACTORY	• 125 MEDICAL	175 SLIDING	
• 021 BLOWER	074 FAILURE	126 MEDICINE	• 176 SMOKE	226 0
• 022 BOILER	075 FAMILY	127 MICROWAVE	177 SONIC	227 1
023 BOTTOM	• 076 FATHERS	128 MONEY	• 178 SONS	228 1ST
024 BOX	• 077 FENCE	129 MONITOR	• 179 SOUTH	229 2
025 BREAK	078 FILE	• 130 MOTHERS	180 SPRINKLER	230 2ND
• 026 BUILDING	• 079 FIRE	• 131 MOTION	181 STAMP	231 3
027 BURNER	• 080 FLOOR	132 MOTOR	• 182 STATION	232 3RD
	081 FLOW	133 MJD	183 STEREO	233 4
028 CABINET	082 FOIL		184 STORE	234 4TH
029 CALL	• 083 FOYER	• 134 NORTH	• 185 STORAGE	235 5
030 CAMERA	084 FREEZER	135 NURSERY	186 STORY	236 5TH
031 CAR	• 085 FRONT		187 STRESS	237 6
032 CASE	086 FUR	• 136 OFFICE	188 STRIKE	238 6TH
033 CASH	087 FURNACE	137 OIL	189 SUMP	239 7
034 CCTV		• 138 OPEN	190 SUPERVISED	240 7TH
035 CEILING	088 GALLERY	139 OPENING	191 SUPERVISION	241 8
036 CELLAR	• 089 GARAGE	• 140 OUTSIDE	192 SWIMMING	242 8TH
• 037 CENTRAL	• 090 GAS	141 OVERFLOW	193 SWITCH	243 9
038 CIRCUIT	091 GATE	142 OVERHEAD		244 9TH
039 CLIP	• 092 GLASS		194 TAMPER	
• 040 CLOSED	093 GUEST	143 PAINTING	195 TAPE	250 Custom Word #1
041 COIN	094 GUN	• 144 PANIC	196 TELCO	
042 COLD		145 PASSIVE	197 TELEPHONE	
043 COATROOM	• 095 HALL	• 146 PATIO	198 TELLER	251 Custom Word #2
044 COLLECTION	• 096 HEAT	147 PERIMETER	• 199 TEMPERATURE	
045 COMBUSTION	097 HIGH	• 148 PHONE	200 THERMOSTAT	
• 046 COMPUTER	098 HOLDUP	149 PHOTO	• 201 TOOL	252 Custom Word #3
047 CONTACT	099 HOUSE	150 POINT	202 TRANSMITTER	
		151 POLICE	203 TRAP	
• 048 DAUGHTERS	100 INFRARED	152 POOL	204 ULTRA	253 Custom Word #4
049 DELAYED	• 101 INSIDE	• 153 POWER	• 205 UP	
• 050 DEN	102 INTERIOR		• 206 UPPER	
051 DESK	103 INTRUSION	154 QUAD	• 207 UPSTAIRS	254 Custom Word #5
• 052 DETECTOR			• 208 UTILITY	
• 053 DINING	104 JEWELRY			

Note: Bulleted (*) words in **boldface type** are those that are also available for use by the 4285 Voice Module. If using a voice module, and words other than these are selected for alpha descriptors, the voice module will not provide annunciation of those words.

CHARACTER (ASCII) CHART

(For Adding Custom Words)

32 (space)	41)	50 2	59 ;	68 D	77 M	86 V
33 !	42 *	51 3	60 <	69 E	78 N	87 W
34 "	43 +	52 4	61 =	70 F	79 O	88 X
35 #	44 ,	53 5	62 >	71 G	80 P	89 Y
36 \$	45 -	54 6	63 ?	72 H	81 Q	90 Z
37 %	46 .	55 7	64 @	73 I	82 R	
38 &	47 /	56 8	65 A	74 J	83 S	
39 '	48 0	57 9	66 B	75 K	84 T	
40 (49 1	58 :	67 C	76 L	85 U	

Section 6. SYSTEM COMMUNICATION

Report Code Formats

The Report Codes for Alarm, System Status, and Restore for Zones shown in program fields *56-*75 can be selected in field *46 to report to the central station in any of the following formats:

Note: If OUTPUT TO LONG RANGE RADIO (field *27) is enabled, all dialer and long range radio reports will be sent in Contact ID format (see next page), regardless of the selection made in field *46.

The 3+1 and 4+1 Standard formats comprise a 3 (or 4) digit subscriber number and a single digit report code (e.g. Alarm, Trouble, Restore, Open, Close).

The 3+1 and 4+1 Expanded formats comprise a 3 (or 4) digit subscriber number, and a single digit report code, followed by a second line where the report code is repeated 3 (or 4) times and followed by another number (normally the zone number) or user ID related to that report.

The 4+2 formats comprise either a 4 digit subscriber number and two digit report code, or a 4 digit subscriber number and single digit report code, immediately followed by the zone number (normally) or user ID.

Report	3+1, 4+1 Standard	3+1, 4+1 Expanded	4+2
Alarm	SSS(S) A	SSS(S) A AAA(A) Z	SSSS AZ
Trouble	SSS(S) T	SSS(S) T TTT(T) t	SSSS Tt
Bypass	SSS(S) B	SSS(S) B BBB(B) b	SSSS Bb
AC Loss	SSS(S) E	SSS(S) E EEE(E) A _C	SSSS EA _C
Low Batt	SSS(S) L	SSS(S) L LLL(L) L _B	SSSS LL _B
Open	SSS(S) O	SSS(S) O OOO(O) U	SSSS OU
Close	SSS(S) C	SSS(S) C CCC(C) U	SSSS CU
Test	SSS(S) G	SSS(S) G GGG(G)g	SSSS Gg
Restore	SSS(S) R	SSS(S) R RRR(R) Z	SSSS RZ
Alarm AC Restore	SSS(S) R _A	SSS(S) R _A R _A R _A R _A (R _A)A _C	SSSSR _A A _C
LoBat Res.	SSS(S) R _L	SSS(S) R _L R _L R _L R _L (R _L)L _B	SSSS R _L L _B
Trouble Res.	SSS(S) R _T	SSS(S) R _T R _T R _T R _T (R _T)t	SSSS R _T t
Bypass Res.	SSS(S) R _B	SSS(S) R _B R _B R _B R _B (R _B)b	SSSS R _B b

Where:

- | | |
|--|--|
| SSS or | C = Close Code-1st Digit |
| SSSS = Subscriber ID | U = User Number (1st & 2nd digits) |
| A = Alarm Code-1st digit | Gg = Test Code (1st & 2nd digits) |
| Z = Typically Zone Number*-2nd digit | R = Restore Code (Alarm)1st & 2nd digits |
| Tt = Trouble Code (1st & 2nd digits) | R _T t = Restore Code (Trbl)1st & 2nd digits |
| Bb = Bypass Code (1st & 2nd digits) | R _B b = Restore Code (Byps)1st & 2nd digits |
| EA _C = AC Loss Code (1st & 2nd digits) | R _A A _C = Restore Code (AC)1st & 2nd digits |
| LL _B = Low Battery Code(1st & 2nd digits) | R _L L _B = Restore Code (Bat)1st & 2nd digits |
| O = Open Code-1st Digit | |

Zone numbers for: []&[#], or [B] = 7 [1] + [*], or [A] = 95
 Duress = 8 [3] + [#], or [C] = 96
 Tamper = 9

(continued)

The Ademco Contact ID Reporting format comprises a 4 digit subscriber number, 1 digit event qualifier ("new" or "restore"), 3 digit event code, 2 digit "00", and 3 digit zone, contact ID, user, or system status number.

Ademco Contact ID Reporting takes the following format:

CCCC Q EEE GG ZZZ

where: CCCC = Customer (subscriber) ID

Q = Event qualifier, where: E = new event , and R = restore

EEE = Event code (3 hexadecimal digits, defined in the table below)

GG = Always 00.

ZZZ = Zone/contact ID number reporting the alarm, or user number for open/close reports. System status messages (AC Loss, Walk Test, etc.) contain zeroes in the ZZZ location.

TABLE OF CONTACT ID EVENT CODES

Code	Definition
110	Fire Alarm
121	Duress
122	Silent Panic
123	Audible Panic
131	Perimeter Burglary
132	Interior Burglary
134	Entry/Exit Burglary
135	Day/Night Burglary
150	24 Hour Auxiliary
301	AC Power
302	Low System Battery
333	Expansion Module Fail
353	LR Radio Trouble
373	Fire Loop Trouble

Code	Definition
374	Exit Alarm
380	Trouble (global)
381	Loss of Supervision - RF
383	Sensor Tamper
384	RF Transmitter Low Battery
401	O/C By User
406	Cancel by User
407	Remote Arm/Disarm (Download)
408	Quick Arm
441	Armed STAY
570	Bypass
601	Test - Manually Triggered
602	Periodic Test

Section 7. REMOTE PROGRAMMING AND CONTROL (DOWNLOADING)

General Information

The *Ademco via30+* can be remotely programmed from an IBM compatible Personal Computer (PC), a Hayes Modem, and Ademco's V-LINK® Software (see below).

Such programming is protected against compromise by someone attempting to defeat the system, by using multi-levels of security protection:

1. **Security Code Handshake:** An 8-digit download ID code must be matched between the control and the downloader .
2. **Site Initiated Remote Programming:** The installer or subscriber initiates the callback from the subscriber premises (by pressing MASTER CODE + # + 1) while disarmed. All parameters can then be downloaded via the phone lines using a personal computer.
3. **Station Initiated Remote Programming:** The operator calls the site from your office to initiate the download call. The control hangs up and then calls back the PC via the preprogrammed telephone number. The unit can then be uploaded, downloaded, or controlled from your office .
4. **Data Encryption:** Data passed between the PC and the control is encrypted for security so that it is very difficult for a foreign device tapped into the phone line to take over communication and substitute system compromising information.

Equipment Required

At the premises:

- *Ademco via30+* and console.

At the installer's office/home:

- An IBM PC compatible computer.
- *Either:* A Hayes brand Smartmodem 1200 [Level 1.2 or higher external or Level 1.1 or higher (with 4 position DIP switch) internal style],
or: A Hayes brand Optima 24 Plus FAX96 Modem (set Aux Modem Command to: X&D2&C1&Q0).
- A No. 4130PC Downloading Software Diskette (Rev. 3.0, or higher).
- Appropriate interconnecting cables.

Programming

The downloading system can perform many functions when in communication with the control unit. Besides uploading and downloading, the status of the system can be observed and various commands can be initiated, as follows:

- Arm the System in the Away Mode; Disarm the System.
- Bypass a Zone.
- Force the System to Accept a New Program Download.
- Shut Down Communication (dialer) Functions (non-payment of monitoring fees in an owned system).
- Shut Down all Security System Functions (non-payment for a leased system).
- Inhibit Local Keypad Programming (prevents account takeover).
- Command the System to Upload a Copy of its Resident Program to the office.
- Read: Arming Status, AC Power Status, Lists of Faulted Zones, Bypassed Zones, Zones Currently in Alarm, Zones Currently in Trouble, and RF Sensors with Low Battery Conditions.

Notes: After the control and the PC have established valid communication, each console on the system will become inactive and will display "CC" or "MODEM COMM.". The control, however, will still be scanning its zones and looking for alarms. If an alarm does occur, after communication is broken off, alarms are sounded and the proper dialer reports are sent to the central station. The consoles will become active after the download communication is terminated. The detailed operation of the download functions is covered in the installation instructions for the 4130PC Downloading Software Diskette.

Remote Programming Advisory Notes

- Alarm and trouble reporting may be delayed during the time that the system and the Downloader are linked to each other following a valid exchange of codes, but the proper message will get through to the Central Station after the link is broken.

(continued)

- Keypad entries are ignored during the time interval stated above.
- A copy of the program downloaded may be produced from the IBM PC compatible computer, using the product's internal report generator, when an optional printer is connected (consult your PC manual for proper printer and connections).
- Program Upload Time—One minute fifteen seconds for a complete program.
- Program Download Time—Depends on changes. Average time, one minute.

Section 8. SYSTEM OPERATION

SECURITY CODES

Master Code The installer programs the 4-digit Master Code initially as part of the programming procedure (see *PROGRAMMING THE SYSTEM*). The factory default Master code is "4111".

The Master code can permit re-entry into the programming mode and also, in normal operation mode, is used to enter the user codes, which also allow access to the normal functions of the system.

See the *PROGRAMMING* section for information on exiting the programming mode via fields *98 or *99.

User Codes In normal operation mode, the Master security code can be used to assign up to six secondary security codes. It can also be used to remove secondary codes from the system (individually).

To assign (or change) a Secondary security code, enter:

Master Code + [CODE] key+ User # (2, 3, 4, 5, 6, or 7) + desired Secondary Code

The system will emit a single beep when each secondary code has been successfully entered.

To delete a Secondary security code, enter:

Master Code + [CODE] key + User # (2, 3, 4, 5, 6, or 7)

Notes:

- All Master and Secondary security codes permit access to the system for arming, disarming, etc.
- If a secondary code is inadvertently repeated for different users, or one user's code is another's duress code (4th digit increased by 1), the lower user number will take priority.
- Opening and closing reports are sent for the Master code as No. 1. User codes are sent as Nos. 2 through 7 respectively.

KEYPAD FUNCTIONS

General Information Note that if QUICK ARM is enabled (field *21), the [#] key can be pressed instead of entering the security code, for any of the arming procedures (Away, Stay, Instant, Maximum, etc.). The security code is *always* required, however, when disarming the system.

The keypad allows the user to arm and disarm the system, and perform other system functions, such as bypassing zones, and display zone descriptors. Zone and system conditions (alarm, trouble, bypass) are displayed in the Display Window.

When an alarm occurs, console sounding and external sounding will occur, and the zone(s) in alarm will be displayed on the console. Pressing any key will silence the console sounder for 10 seconds. Disarming the system will silence both console and external sounders. When the system is disarmed, any zones that were in an alarm condition during the armed period will be displayed (memory of alarm). To clear this display, simply repeat the disarm sequence (enter the security code and press the OFF key) *twice*.

The consoles also feature chime annunciation, and 3 panic keys, or key pairs, (for silent, audible, fire, or personal emergency alarms) which can notify the central station of an alarm condition, if that service is connected.

Arming Functions

The following is a brief list of system commands. For detailed information concerning system functions, refer to the User's Manual.

- Disarmed, Not Ready** Before arming, the system must be in the READY condition (all zones must be intact). If the "NOT READY" message appears, press the READY [*] key to display faulted zones.
- Arming Away** Enter code + AWAY [2].
- Arming Stay** Enter code + STAY [3].
- Arming Instant** Enter code + INSTANT [7].
- Arming Maximum** Enter code + MAXIMUM [4].
- Disarming** Enter code + OFF [1].
- Bypassing Zones** Enter code + BYPASS [6] + zone number(s).
- Forced (Quick) Bypass** (If enabled) To bypass all faulted zones at once, use "Forced Bypass" method:
Enter code + BYPASS (then stop).
- Chime Mode** Enter code + CHIME [9].
To turn chime mode off, enter code + CHIME again.

SUMMARY OF ARMING MODES

Mode	Features for Each Arming Mode			
	Exit Delay	Entry Delay	Perimeter Armed	Interior Armed
AWAY	Yes	Yes	Yes	Yes
STAY	Yes	Yes	Yes	No
INSTANT	Yes	No	Yes	No
MAXIMUM	Yes	No	Yes	Yes

Panic Keys

There are three panic key pairs and (on some consoles) lettered keys (shown below) that, if programmed, can be used to manually initiate alarms and send a report to the central station. Each can be individually programmed for 24 Hour Silent, Audible, Personal or Fire Emergency responses. The panic function is activated when both keys of the appropriate key pair are pressed at the same time, or the appropriate lettered key is pressed for at least 2 seconds.

The panic functions are identified by the system as follows:

KEYS	Displayed as Zone
[1] & [*], or [A]	95
[*] & [#], or [B]	07
[3] & [#], or [C]	96

- Notes:**
- Keys [A], [B], [C] are not on all consoles.
 - Key [D], if present, is not active here.

IMPORTANT: For the Silent Panic function to be of practical value, the system must be connected to a central station.

Relay Outputs (if used)

If relay outputs are provided (via a 4204 or 4229), two keypad entries available to the user are included among the system operation choices that may be programmed. They can manually activate or deactivate the relay(s) for starting or stopping some action, such as turning lights on or off, etc.

These entries are: **Security Code + [#] + [7]**
and **Security Code + [#] + [8]**

Note: Whichever entry is used to start/stop the action cannot also be used to stop/start it. The opposite action must either be performed by the other keypad entry or by some other event or operation offered in the programming section.

For some examples, see pages 26 and 45.

(continued)

**Exit Alarm
Displays
(If programmed)**

- A display of "CANCELED ALARM" or "CA" and a zone indication will appear if an exit or interior zone contained a fault during closing at the time the exit delay ended (e.g., exit door left open), *but the system was disarmed during the immediately following entry delay time*. The alarm sounder and keypad sound continuously, but stop when the system is disarmed. No message will be transmitted to the central station.
- A display of "EXIT ALARM" or "EA" and a zone indication will appear if an exit or interior zone contained a fault during closing at the time the exit delay ended, *but the system was NOT disarmed during the immediately following entry delay time*. The alarm sounder and keypad sound continuously until the system is disarmed (or timeout occurs). An "exit alarm" message is sent to the central station.
- The "EXIT ALARM" display, etc. will also result if an alarm from an exit or interior zone occurs within two minutes after the end of an exit delay.

In any of the above cases, a second OFF sequence (code plus OFF key) will clear the display.

TROUBLE CONDITIONS

General Information

The word "CHECK" on the Keypad's display, accompanied by a rapid "beeping" at the Keypad, indicates that there is a trouble condition in the system. The audible warning sound can be silenced by pressing any key. Instruct users to call for service immediately upon seeing any of the following messages.

"Check" and "Battery" Displays

- A display of "CHECK" and one or more zone numbers indicates that a problem exists with the displayed zone(s) and requires attention.

When the problem has been corrected, the display can be cleared by entering the OFF sequence (code plus OFF key) twice.

- If there are wireless sensors in the system, the CHECK condition may also be caused by some change in the environment that prevents the receiver from hearing a particular sensor.
- A display of "BAT" with no zone number indicates that the system's main standby battery is weak.
- A display of "BAT" with a zone number and a once per minute "beeping" at the keypad indicates that a low battery condition exists in the wireless sensor displayed (zone "00" indicates a wireless keypad). If the battery is not replaced within 30 days, a CHECK display may occur.

Note: Some wireless sensors contain a non-replaceable long-life battery which requires replacement of the entire unit at the end of battery life (e.g., Nos. 5802, 5802CP, 5803).

Power Failure

- If there is no keypad display at all, and the POWER Indicator (if present) is not lit, operating power for the system has stopped and the system is inoperative.
- If the message "AC LOSS" or "NO AC" is displayed, and the POWER indicator (if present) is off, the keypad is operating on battery power only.
- If the battery standby capacity is used up during a prolonged AC power outage, the control's auxiliary power will shut down to minimize deep discharge of the battery.

Other Displays (Fixed Word Keypads)

- dI If this remains displayed for more than 1 minute, the system is disabled.
- CC The system is in communication with the central station for change of function or status verification.
- FC A communication failure has occurred.
- OC The keypad is not receiving signals from the control panel and sees an open circuit.

Section 9. TESTING THE SYSTEM

Procedure After installation is completed, the Security System should be carefully tested.

1. With the System in the disarmed state, check that all zones are intact. If **NOT READY** is displayed, press the [*] key to display the faulted zone(s). Restore faulted zone(s) if necessary, so that **READY** is displayed. Fault and restore every sensor individually to assure that it is being monitored by the system.
2. Enter the **security code** and press the **TEST** key. The outside sounder will sound for 1 second. The console should sound 3 beeps each time a contact is faulted. A test report should be transmitted (if programmed) to the Central Station immediately. If the backup battery is discharged or missing, the sounder may not turn on and a **LOW BATTERY** report will be transmitted with a **TEST** report. The console will beep once per minute as a reminder that the system is in the Test Mode.

To turn off the test mode enter the **security code** and press the **OFF** key.

Note: For 5800 systems, triggering a zone set to Arm Away, Arm Stay, or Disarm will take the system out of **TEST** and cause that action.

Alarm messages will be sent to the central station during the following tests 3 and 4. Notify them in advance that tests will be in progress.

3. Arm the system and fault one or more zones. After 15 seconds (if optional dialer delay is selected), silence alarm sounder(s) by entering the **code** and pressing **OFF**. Check Entry/Exit delay zones.
4. Check the keypad-initiated alarms that are in the system by pressing the Panic key pairs. If the system has been programmed for audible emergency, the console will emit a steady alarm sound, and **ALARM and zone number** will be displayed. Silence the alarm by entering the **security code** and pressing **OFF**.

If the system has been programmed for silent emergency, there will be no audible alarms or displays, but a report will be sent to the central station.

5. If output relays have been installed, test their programmed action.
6. Notify the central station when all tests are finished, and verify results with them.
7. To test the wireless part of the system and the RF Receiver, 3 additional test modes are available:
 - a. **HOUSE ID SNIFFER MODE** (*not applicable to, or necessary with, 5800 RF system*): By pressing **Master code + # + 2**, a house code "sniffer" mode is enabled. The console will display the house code of any RF transmission it receives. In this way, you can check that you are not using the same house code as any nearby system (suggested test period: approx. 2 hrs). This mode can be exited by keying the **Master code + OFF**.
 - b. **TRANSMITTER SNIFFER MODE**: Pressing **Master code + # + 3** initiates a procedure to check that all transmitters have been properly programmed. The console will display all zone numbers of wireless units programmed into the system. As the system receives a signal from each of the transmitters, the zone number of that transmitter will disappear from the display. The transmitter codes may be checked upon installation, or in an installed system. All the wireless addresses should disappear after about 1-1/2 hours. This mode can be exited by keying **Master code + OFF**. (**Note:** With a 5800 RF system, a transmitter not learned will not turn off its zone number.)
 - c. **GO/NO GO TEST MODE**: By pressing **Master code + # + 4**, a mode similar to the user test mode (code + **TEST**) is entered, but the wireless receiver gain is reduced. Checking in this mode assists in determining good mounting locations for the transmitters when the system is being installed and verifies that the RF transmission has sufficient signal amplitude margin for the installed system. Exit the mode by entering **Master code + OFF**.

THE TEST MODE WILL BE AUTOMATICALLY TERMINATED AFTER 4 HOURS
IF THE INSTALLER OR USER DOES NOT MANUALLY TERMINATE IT.

This insures that Fire and Panic zones will not remain disabled.

TROUBLESHOOTING GUIDE

S Y S T E M		
SYMPTOM	POSSIBLE CAUSE	REMEDY
1. Transmitted signal not received at 4281/5881.	1a. Transmitter or 4281/5881 not properly powered. 1b. Transmitter and 4281 not set to same house code. 1c. 5827 not being received by 5881. 1d. Strong local RF interference (frequent or prolonged lighting of indicator LED on 4281/5881 circuit board....occasional random flicker is ok). 1e. Transmitter located too far from 4281/5881. 1f. Metal shielding between transmitter and 4281/5881. 1g. Transmitter malfunctioning. 1h. 4281/5881 malfunctioning. 1i. Transmitter number (zone) not programmed.	1a. Check or change transmitter's battery. Check <i>Ademco via30+'s</i> AC power. 1b. Check code switches inside transmitter. Must match with RF House Code programmed in <i>Ademco via30+</i> . 1c. House code for 5827 must be programmed into <i>Ademco via30+</i> . 1d. Relocate 4281. 1e. Move transmitter or 4281/5881. 1f. Check for large metal obstructions, then relocate transmitter if necessary. 1g. Verify by activating 4281/5881 with another, similar transmitter. If O.K. now, return defective transmitter. 1h. Verify by making sure other transmitters cannot activate 4281/5881. If defective, replace and return original 4281/5881. 1i. Verify programming.
2. Transmitter zone number appears during Transmitter Sniffer mode, but does not clear.	2a. Transmitter zone type (ZT) is set to 00 (Not Used). 2b. Transmitter battery not installed. 2c. 5700 System transmitter's DIP switch not set properly (house ID and transmitter ID). 2d. 5800 System transmitter not "learned" in system. 2e. With 5700 System, no response at all to any transmitter.	2a. Set ZT to a valid active zone type in field *56. 2b. Install proper battery. 2c. Check and set the DIP switch. 2d. "Learn" unit in field *56 or *83. 2e. Check 4281 receiver. It must be Rev. D or later and have "N5334V1" marked on the large integrated circuit near the connector.
3. Low Battery message on console.	3a. "Bat" alone. 3b. "Bat" + "00". 3c. "Bat" + "nn".	3a. System battery is low or missing. 3b. Remote RF keypad battery is low. 3c. Transmitter for zone nn has a low battery.
4. Periodic beep(s) from console.	4a. System is in TEST mode. 4b. A transmitter low battery has occurred and is displayed. 4c. A supervision CHECK has occurred.	4a. Enter "Code" + OFF to exit TEST mode. 4b. Enter "Code" + OFF and replace the battery. 4c. Check the transmitter indicated. Restore communication to the receiver to cancel the condition.
5. With 5800 System, no response to a transmitter in normal operation, although zone number clears during Transmitter Sniffer mode.	Put control in TEST mode. If zone does not respond, try operating the tamper switch or another input to the transmitter. 5a. If another input causes the zone to be displayed, the wrong input was "learned" when programming. 5b. If no response at all from this transmitter, this physical transmitter has not been learned by the system. Transmitter Sniffer display is being cleared by another unit programmed for this zone.	5a. Delete input's serial number (not the zone), and learn the proper input (see field *56). 5b. Determine which transmitter is programmed for this zone and reprogram as necessary.
6. Nuisance or phantom alarm.	6a. Sensors not properly installed, wired, or monitored. 6b. Nearby neighbor has 5700 system (4281) with same house code. 6c. Universal transmitter (5715/5817) programmed wrong.	6a. Check installation to see if in accordance with established procedure. 6b. Check with central monitoring station for neighbors with systems. Range can be 300 feet. Change house code if necessary. 6c. Check programming switches on transmitter.

(continued)

TROUBLESHOOTING GUIDE (continued)

S Y S T E M (continued)		
SYMPTOM	POSSIBLE CAUSE	REMEDY
7. Intrusion alarm for no apparent reason.	7a. Protected door or window opened while system armed. 7b. Improper user operation of exit/entry delays. 7c. Magnets located too far from switches, and/or doors and windows not properly aligned. 7d. Magnetic contacts improperly connected or wire broken. 7e. Entry door programmed as "instant". 7f. Loose fitting door or window being rattled by wind or vibrations.	7a. Check with all occupants of protected home. 7b. Check setting of entry delay . Exit delay is 15 seconds longer than the entry delay time. Remind user of same. 7c. Check all openings for proper switch and magnet orientation. 7d. Check wiring connections. Be sure wires are properly stripped and tightly fastened to screw terminals. 7e. Check and revise program. Reprogram transmitter number. 7f. Mount magnet closer to contact.
8. Repeated low battery signal.	8a. Transmitter located where temperature drops below 32° F. 8b. Poor quality or unspecified battery in transmitter. 8c. Transmitter malfunctioning.	8a. Change location. Use magnetic contacts to protect opening. 8b. Check battery. Use only 9V Duracell MN1604 or equivalent for 5700 System. Use only 3V lithium for 5800 System. 8c. Replace faulty transmitter.
9. Local bell and console sound continuously at arming.	9. Exit or interior zone contained a fault at end of Exit Delay (e.g., Exit door left open). <p style="text-align: center;"><i>The "Exit Alarm" display, etc. will also result if an alarm from an exit or interior zone occurs within two minutes after the end of an exit delay. —————></i></p>	9a. If system disarmed <i>before</i> ensuing entry time runs out, "CA" or "Cancelled Alarm" will be displayed. Sounding will stop. 9b. If system <i>not</i> disarmed before entry time ends, "EA" or "Exit Alarm" will be displayed and Exit Alarm message will be sent to central station. Sounding will continue until system is disarmed or timeout occurs. Clear display by entering code + OFF a second time. Avoid fault when rearming.

C O N T R O L		
SYMPTOM	POSSIBLE CAUSE	REMEDY
1. "AC POWER" light off or "NO AC" displayed.	1a. Interrupted AC power supply.	1a. Check transformer connection and power line circuit breaker.
2. Digital communicator message not being received.	2a. <i>Ademco via30+</i> in TEST mode. 2b. Telephone connection not secure. 2c. Telephone number in program needs prefix or access code. 2d. Telephone call to central monitoring station requires operator assistance. 2e. Digital communicator malfunctioning.	2a. Remove from TEST mode. 2b. Check all connections. 2c. Program prefix or access code into <i>Ademco via30+</i> . 2d. <i>Ademco via30+</i> system cannot work in this situation. 2e. Check with a different <i>Ademco via30+</i> .
3. Does not arm properly.	3a. Ready light not on.	3a. Try Bypass arming.
4. <i>Ademco via30+</i> doesn't respond to keystrokes on console.	4a. "CC" or "MODEM COMM" displayed. 4b. "dl" or "System Busy" displayed. 4c. "E4" or "E8" displayed.	4a. System is in communication with downloader at central station. Wait until download session is finished. 4b. System has just been powered and is in its one minute initialization. To bypass this time, press '#' + '0'. 4c. More zones have been programmed than the zone expansion modules can handle. Delete some zones or use a higher capability RF receiver.

S M O K E D E T E C T O R		
SYMPTOM	POSSIBLE CAUSE	REMEDY
1. Detector alarms, no apparent reason.	1a. Dust, dirt in sensing chamber. 1b. Improper location. 1c. Unit malfunctioning.	1a. Clean unit's sensing chamber with vacuum cleaner per unit's instructions. 1b. See unit's instructions for locations to avoid. Relocate as necessary. 1c. Replace detector.
2. Detector's siren sounds.	2a. Unit not receiving required power. 2b. Unit malfunctioning.	2a. Check for proper installation of battery. Try new battery. 2b. Replace detector.

Section 10. SPECIFICATIONS AND ACCESSORIES

SPECIFICATIONS

Ademco via30+ SECURITY CONTROL

- 1. Physical:** 12-1/2" W x 14-1/2" H x 3" D (318mm x 368mm x 76mm)
- 2. Electrical:**
VOLTAGE INPUT: 16.5VAC from plug-in 25VA transformer, Ademco No. 1321/TF2 (in U.S.A.)
Note: For Canadian installations, a No. 1321CN transformer must be used.
RECHARGEABLE BACK-UP BATTERY: 12VDC, 4AH (Gel type), Ademco No. 467.
Charging Voltage: 13.8VDC.
Note: For California fire alarm installations, see the CSFM battery back-up requirements on page 49.
ALARM SOUNDER: 12V, 2.0Amp output can drive 12V BELLS or can drive one or two 702 (**series** connected) self-contained 20-watt sirens. Do **not** connect two 702s in parallel.
AUXILIARY POWER OUTPUT: 12VDC, 500mA max. Interrupts for smoke detector reset.
Note: For UL installations, Alarm Sounder plus Auxiliary Power currents should not exceed 600mA total.
STANDBY TIME: 5 HRS with Auxiliary load of 500mA (using 4AH battery). To determine total standby battery load, add 100mA to total Aux. power output and remote console currents.
FUSE: Battery (3A) No. 90-12

3. Communication:

FORMATS SUPPORTED:

Ademco Express,

10 characters/sec, DTMF (TouchTone) Data Tones, 1400/2300Hz ACK, 1400Hz KISSOFF.

Ademco Contact ID Reporting,

10 characters/sec., DTMF (TouchTone) Data Tones, 1400/2300Hz ACK, 1400Hz KISSOFF.

Ademco Low Speed, 10 pulses/sec, 1900Hz Data Tone, 1400Hz ACK/KISSOFF.

Radionics/SESCO, 20 pulses/sec, 1800Hz Data Tone, 2300Hz ACK/KISSOFF.

Can report 0-9, B-F

Line Seize: Double Pole

FCC Registration No.: AC 398U-68192-AL-E

Ringer Equivalence: 0.7B

4127 REMOTE CONSOLE

- 1. Physical:** 5-5/8" W x 4-11/16" H x 7/8" D (143mm x 119mm x 22mm)
- 2. Electrical:** Voltage Input: 12VDC, Current Drain: 20mA
- 3. Interface Wiring:** To control panel's console connection points.
RED: 12VDC input (+) aux pwr GREEN: Data Out to Control
YELLOW: Data In from Control BLACK: Ground

4137AD & 5137AD REMOTE CONSOLES

- 1. Physical:** 8-2/5" W x 4-3/4" H x 1-1/10" D (213mm x 121mm x 28mm)
- 2. Electrical:** Voltage Input: 12VDC, Current Drain: 60mA (4137AD)
90mA (5137AD)
- 3. Interface Wiring:**
RED: 12VDC input (+) aux pwr
BLUE: 18VDC input from optional No 1350 or 1360 Power Pack (not usable for UL installations)
GREEN: Data Out to Control
YELLOW: Data In from Control
BLACK: Ground and (-) connection from optional No. 1350 or 1360 Power Pack

- 6127
REMOTE CONSOLE**
1. **Physical:** 5-3/4" W x 4-3/4" H x 1" D (146mm x 121mm x 26mm)
 2. **Electrical:** Voltage Input: 12VDC, Current Drain: 20mA
 3. **Interface Wiring:** Same as 4127 above.
- 6128
REMOTE CONSOLE**
1. **Physical:** 5-3/4" W x 4-3/4" H x 1" D (146mm x 121mm x 26mm)
 2. **Electrical:** Voltage Input: 12VDC, Current Drain: 30mA
 3. **Interface Wiring:** Same as 4127 above.
- 6137
REMOTE CONSOLE**
1. **Physical:** 6-1/4" W x 4-3/4" H x 1" D (159mm x 121mm x 26mm)
 2. **Electrical:** Voltage Input: 12VDC, Current Drain: 85mA
 3. **Interface Wiring:** Same as 4127 above.
- 6138 & 6139
REMOTE CONSOLES**
1. **Physical:** 6-1/4" W x 4-3/4" H x 1" D (159mm x 121mm x 26mm)
 2. **Electrical:** Voltage Input: 12VDC, Current Drain: 100mA
 3. **Interface Wiring:** Same as 4127 above.
- 4281L, 4281M, 4281H
RF RECEIVERS
(5700 System)
and
5881L, 5881M, 5881H
RF RECEIVERS
(5800 System)**
1. **Physical:** 7-3/8" (188mm)W
4-3/8" (112mm) H
10-7/8" (277mm) H ←with antenna
1-7/16" (37mm) D
 2. **Electrical:** Voltage Input: 12VDC Current Drain: 35mA
 3. **Interface Wiring:** Same as 4127 above.
 4. **Range:** 200ft (60m) nominal indoors from wireless transmitters (the actual range to be determined with system in TEST mode).
 5. **Zones:** With the *Ademco via30+*:
4281L: accepts up to 4 transmitters
4281M /5881L: accepts up to 8 transmitters
5881M: accepts up to 16 transmitters
4281H/5881H: accepts up to 30 transmitters
- 5800TM
TRANSMITTER
MODULE
used with 5827BD
Wireless
Bidirectional Keypad**
1. **Physical:** 2-1/4" W x 4-1/8" H x 7/8" D (57mm x 105mm x 22mm)
 2. **Electrical:** Voltage Input: 12VDC Current Drain: 20mA
 3. **Interface Wiring:** Same as 4127 above.
- 4219
WIRED EXPANSION
MODULE**
1. **Physical:** 6-1/2" W x 4-1/4" H x 1-1/4" D (169mm x 108mm x 32mm)
 2. **Electrical:** Voltage Input: 12VDC Current Drain: 35mA
 3. **Interface Wiring:** Same as 4127 above.
 4. **8 EOLR Loops (A-H):** Loop A can be set for fast (10-15msec) response to an open.
- 4204
RELAY MODULE**
1. **Physical:** 6-1/2" W x 4-1/4" H x 1-1/4" D (169mm x 108mm x 32mm)
 2. **Electrical:** Voltage Input: 12VDC Current Drain: 15mA (Relays off)
180mA (Relays on)
 3. **Interface Wiring:** Same as 4127 above.
 4. **Four Output Relays:** SPDT Contacts,
Rating: 2A max at 28VDC/AC
(120VAC for non-UL installations)
- 4229
WIRED EXPANSION/
RELAY MODULE**
1. **Physical:** 6-1/2" W x 4-1/4" H x 1-1/4" D (169mm x 108mm x 32mm)
 2. **Electrical:** Voltage Input: 12VDC Current Drain: 35mA (Relays off)
100mA (Relays on)
 3. **Interface Wiring:** Same as 4127 above.
 4. **8 EOLR Loops (A-H):** Loop A can be set for fast (10-15msec) response to an open.
 5. **Two Output Relays:** SPDT Contacts,
Rating: 2A max at 28VDC/AC
(120VAC for non-UL installations)

**4285
VOICE MODULE**

1. **Physical:** 6-1/2" W x 4-1/4" H x 1-1/4" D (169mm x 108mm x 32mm)
2. **Electrical:** Voltage Input: 12VDC Current Drain: 160mA
3. **Device Address:** Permanently set to address 4.
4. **Interface Wiring:** Same as 4127 above.
5. **Telephone Line Connections:** See information accompanying 4285.

ACCESSORIES (COMPATIBLE DEVICES)

Accessories	No. 1321/TF2	16.5VAC, 25VA Plug-In Transformer (in U.S.A.)
	No. 1321CN	16.5VAC, 25VA Plug-in Transformer (in Canada)
	No. 702	Self-contained 20 watt Siren (indoor or outdoor).
	No. 740	Extremely loud Piezoelectric Alarm Sounder, 122dB output (indoor or outdoor).
	No. 5716BR	Brown Cases and Mounting Brackets (3) for 5716, 5716WM.
	No. 5799	Pkg. of 8 Magnets for 5716
	No. 7720ECP	Long Range Radio (Set Device Address to 3).
	<u>System Sensor:</u>	
	PA400B	Piezoelectric Alarm Sounder, 90dB output (mounts in single-gang box).
	1412	4-wire Ionization Products of Combustion Detector
	2412	4-wire Photoelectric Smoke Detector
	2412TH	4-wire Photoelectric Smoke Detector w/135°F (57°C) Heat Detector
	A77-716B	EOL Relay Module (Supervisory Module for wired fire zone)

**5700 RF System
Wireless Transmitters
for
4281**

5701 Panic Transmitter

Programmable for either silent or audible 24 hour alarm (can be DIP switch programmed for zones 62 or 63).

5706 & 5707 Wireless Photoelectric Smoke Detectors

One piece smoke detectors with built-in transmitter (DIP switch programmable for zones 48-55). Built-in UL Listed 85 dB piezoelectric alarm sounder and audible low battery warning.

5711 Slimline Door/Window Transmitter

Can be used with any closed circuit sensor.

5715WH (White) Universal Transmitter

DIP switch selectable for fast response, open or closed sensor usage, and has a tamper protected cover. Use in applications where open circuit heat detectors are needed or where fast response devices are employed.

5716 Small Door/Window Transmitter

5716WM Small Door/Window Xmtr w/Magnet

Can be used with any open or closed circuit sensor (DIP switch selectable). Features a built-in reed switch.

5742 Audio Discriminator/Transmitter

For use in unoccupied areas to detect the sound of shattering glass when a window is broken. Built-in 5716 type transmitter.

5743 Dual Technology Glass Break Detector/Transmitter

Detects the sound *and* shock vibrations of breaking glass and requires the presence of *both* to initiate an alarm condition transmission. Built-in 5716 type transmitter.

5775 PIR Detector/Transmitter

Dual element passive infrared detector/transmitter with built-in selectable pulse count. DIP switch programmable for zones 32-47. *Note:* There is a 3 minute lock-out between fault transmissions to conserve battery life.

Two interchangeable battery compartments are provided. One accommodates a single battery, and the other, two batteries. Use of the two-battery compartment can double the time between battery replacement.

5727 Wireless Keypad

Can be used to turn the burglary protection on and off, and features the same built-in panic functions as wired consoles for either silent or audible 24 hour alarm. An LED indication lights each time a key is pressed, to verify transmission. The keypad is identified as zone "00" (on wired consoles) when it transmits with a low battery.

5827BD Wireless Bidirectional Console (used with 5800TM Transmitter Module)

Can operate the system similarly to wired consoles and can indicate system status via its 3 LEDs and sounder. Includes 3 panic keys for 24 hour silent or audible alarm. Requires a 5800TM Transmitter Module, to operate in conjunction with system's 4281/5881 receiver. Key programmed, *has no DIP switch*. The console is identified as zone "00" (on wired consoles) when it transmits with a low battery.

5800 RF System Wireless Transmitters for 5881

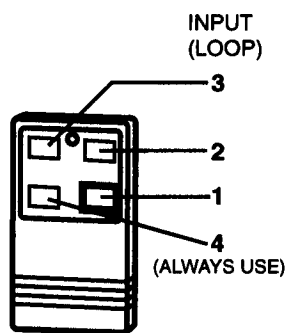

LEARN AS "UR" OR "RF"
5 8 0 1

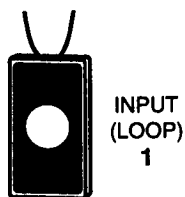

LEARN AS "BR"
5 8 0 2 / 5 8 0 2 C P

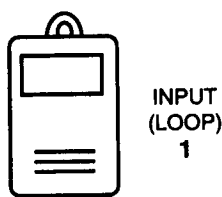

LEARN AS "UR" OR "RF"
5 8 0 2 M N

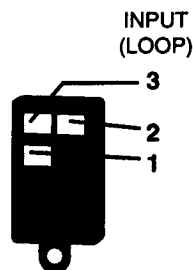

LEARN AS "BR"
5 8 0 3

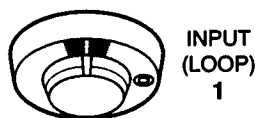

LEARN AS "RF"
5 8 0 6 / 5 8 0 7
(5806 SHOWN)

Notes:

- All of the transmitters described below have one or more unique factory assigned input (loop) ID codes. *Each of the inputs requires its own programming zone* (e.g., a 5803's three inputs require three programming zones).

- Transmitter inputs learned as:

"RF" (Supervised RF) Type send periodic check-in signals, as well as fault, restore and low battery signals. The transmitter must remain within the receiver's range.

"UR" (Unsupervised RF) Type send all the signals that the "RF" Type does, but the control does not supervise the check-in signals. The transmitter may, therefore, be carried off-premises.

"BR" (Unsupervised Button RF) Type only send fault signals. They do not send low battery, restore or check-in signals. The transmitter may be carried off-premises.

5801 Wireless Panic Transmitter

Has four pushbuttons, each with a unique input (loop) code. The control unit's response to each of the buttons is programmable (e.g., Panic, Arm-Stay, Arm-Away, Disarm, etc).

5802 Pendant & 5802CP Belt Clip (Personal Emergency) Transmitters

Their single pushbuttons should usually be programmed for control unit response of 24 Hr Audible or 24 Hr Silent. Other zone responses are possible. Each contains a non-replaceable battery. At the end of the battery's life, the entire unit must be replaced.

5802MN Miniature (Personal Emergency) Transmitter

Its single pushbutton should usually be programmed for control unit response of 24 Hr Audible or 24 Hr Silent. Other zone responses are possible.

5803 Wireless Key Transmitter

Has three pushbuttons, each with a unique input (loop) code. The control unit's response to each of the buttons is programmable (e.g., Arm-Stay, Arm-Away, Disarm, etc.).

Contains a non-replaceable battery. At the end of the battery's life, the entire unit must be replaced.

5806 & 5807 Wireless Photoelectric Smoke Detectors

One piece smoke detectors with built-in transmitter. Built-in UL Listed 85 dB piezoelectric alarm sounder and audible low battery warning.

5816 Door/Window Transmitter

Has two unique input (loop) codes: one for a wired closed circuit contact loop, and the other for a built-in reed switch (used in conjunction with a magnet).

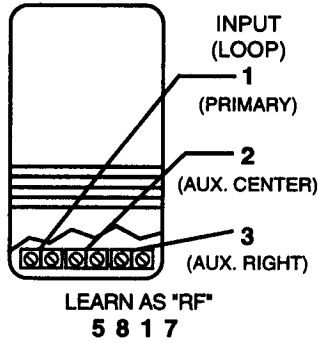
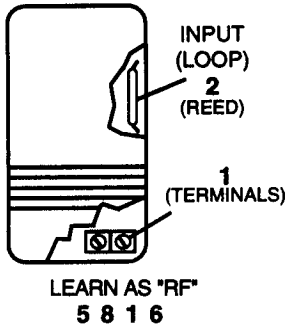

5817 Multi-Point Universal Transmitter

Has three unique input (loop) codes: one for a DIP switch settable "Primary" contact loop, and the others for two "Auxiliary" closed circuit contact loops. The "Primary" loop may be set for: a) Repeating or Single Transmission, b) Normally Open or Normally Closed Circuit, c) Slow or Fast Response, and d) 3 Minute or No Transmission Inhibit.

5818 Recessed Transmitter

A reed switch magnetic contact sensor that is easily concealed in the frame and edge of a door or window. Has a single unique input (loop) code.

5827 Wireless Keypad

Can be used to turn the burglary protection on and off, and features the same built-in panic functions as wired keypads for either silent or audible 24 hour alarm. An LED indication lights each time a key is pressed, to verify transmission. The keypad is identified as zone "00" on wired keypads when it transmits with a low battery.

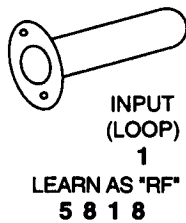

5827BD Wireless Bidirectional Keypad (used with 5800TM Transmitter Module)

Can operate the system similarly to wired keypads and can indicate system status via its 3 LEDs and sounder. Includes 3 panic keys for 24 hour silent or audible alarm. Requires a 5800TM Transmitter Module, to operate in conjunction with system's 4281/5881 receiver. Key programmed, *has no DIP switch*. The keypad is identified as zone "00" on wired keypads when it transmits with a low battery.

SET HOUSE CODE
5 8 2 7

SET HOUSE CODE
5 8 2 7 B D

5849 Glass Break Detector/Transmitter

When sound and shock of breaking glass are detected by this unit at the same time, a wireless alarm will be transmitted via the unit's unique input code. Separate alarm and cover tamper signals permit 24 hour monitoring.

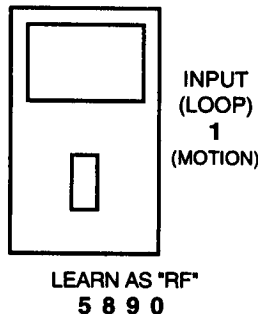
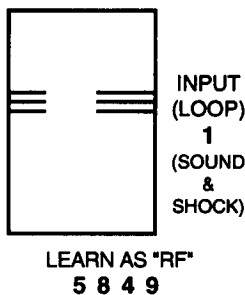

5890 PIR Detector/Transmitter

Has unique input code for its dual element passive infrared detector/transmitter with built-in selectable pulse count.

Note: There is a 3 minute lock-out between fault transmissions to conserve battery life.

TO THE INSTALLER

Regular maintenance and inspection (at least annually) by the installer and frequent testing by the user are vital to continuous satisfactory operation of any alarm system.

The installer should assume the responsibility of developing and offering a regular maintenance program to the user as well as acquainting the user with the proper operation and limitations of the alarm system and its component parts. Recommendations must be included for a specific program of frequent testing (at least weekly) to insure the system's proper operation at all times.

OUTPUT RELAY EXAMPLES TABLE

ACTION DESIRED	RELAY ACTION	START			STOP	
	A	EV	ZL	ZT	ZL	ZT
Zones in zone list (x) close relay for 2 seconds on alarms.	1	1	x	00	0	00
Zones in zone list (x) close relay for 2 seconds on troubles.	1	3	x	00	0	00
Zones in zone list (x) close relay for 2 seconds on faults*.	1	2	x	00	0	00
<i>*Will activate relay for any zone type plus panics on 5801 whether control is armed or disarmed. (Console panics will not activate a relay with the configurations above.)</i>						
Zones in zone list (x) close relay on alarms and reset at bell timeout or when disarmed.	2	1	x	00	0	36
Zones in zone list (x) pulse relay on alarms and reset at bell timeout or when disarmed.	3	1	x	00	0	36
Zones in zone list (x) close relay on alarms and reset when zone is restored.*	2	1	x	00	x	00
Zones in zone list (x) pulse relay on alarms and reset when zone is restored.*	3	1	x	00	x	00
<i>*Console panics or zone type 23 will not activate a relay with these configurations. The relay can also be activated by troubles or faults by changing the EV (event) accordingly.</i>						
Zones in zone list (x) close relay on alarms and reset when disarmed. (Latching relay for strobes.)*	2	1	x	00	0	22
Zones in zone list (x) pulse a relay on alarms and reset when disarmed.*	3	1	x	00	0	22
<i>*Relay will activate for burglary, fire, and panic alarms if programmed into zone list.</i>						
Close relay after any burglary alarm and reset when disarmed.*	2	0	0	33	0	22
Close relay after any burglary alarm and reset at bell timeout or when disarmed.*	2	0	0	33	0	36
<i>*Response types 06, 08, and 09 will not activate relay. If PULSE relay is desired, enter a 3 in A (action).</i>						
Close relay when ARMED-AWAY, reset when DISARMED.*	2	0	0	21	0	22
Close relay when ARMED-STAY, reset when DISARMED.*	2	0	0	20	0	22
<i>*If PULSED relay is desired, enter a 3 in A (action).</i>						
Close relay for 2 seconds at end of exit delay time after system is armed (Confirmation ding).	1	0	0	31	0	00
Pulse relay at start of entry time and reset when system is disarmed (entry warning).	3	0	0	32	0	22
Close relay for 2 seconds during chime. (Chime mode must be turned on at control.)	1	0	0	38	0	00

(continued)

OUTPUT RELAY EXAMPLES TABLE

ACTION DESIRED	RELAY ACTION	START			STOP	
	A	E V	ZL	ZT	ZL	ZT
Close relay at start of entry time and reset with key entry of security code + # + 7. *	2	0	0	32	0	34
<i>*Can be used to turn on a light when entry door is opened.</i>						
Close relay after any burglary alarm and reset with key entry of security code + # + 8. *	2	0	0	33	0	35
<i>*Can be used to turn on lights in the event of a burglary alarm... (NOTE: Response types 06, 08, and 09 will not activate relay).</i>						
Zones in zone list (x) close relay on alarms and reset with key entry of security code + # + 7. (Possible use with strobe light)	2	1	x	00	0	34
Zones in zone list (x) pulse relay on alarms and reset with key entry of security code + # + 7.	3	1	x	00	0	34
A system low battery detection causes relay to close for 2 seconds. *	1	0	0	42	0	00
An AC loss detection causes relay to close for 2 seconds. *	1	0	0	41	0	00
<i>*The relay will not reset on restoral of low battery or AC power. For this reason, using "close for 2 seconds" in A(action) is recommended.</i>						
Bypassing a zone will cause relay to close for 2 seconds.	1	0	0	40	0	00
Bypassing a zone causes relay to close and will reset with a disarm sequence (code + off.)	2	0	0	40	0	22
Any FIRE alarm causes relay to pulse on and off and will reset with an entry of a disarm sequence (code + off.)	3	0	0	39	0	22
An alarm or trouble condition on any FIRE zone causes relay to close and will reset when condition clears.	1	0	0	09	0	09

DIP SWITCH TABLES FOR 5700 RF SYSTEM WIRELESS DEVICES

House ID Switch Setting for All Devices Except 5716

HOUSE ID	DIP SWITCH SETTINGS				
	1	2	3	4	5
1	UP	UP	UP	UP	dn
2	UP	UP	UP	dn	UP
3	UP	UP	UP	dn	dn
4	UP	UP	dn	UP	UP
5	UP	UP	dn	UP	dn
6	UP	UP	dn	dn	UP
7	UP	UP	dn	dn	dn
8	UP	dn	UP	UP	UP
9	UP	dn	UP	UP	dn
10	UP	dn	UP	dn	UP
11	UP	dn	UP	dn	dn
12	UP	dn	dn	UP	UP
13	UP	dn	dn	UP	dn
14	UP	dn	dn	dn	UP
15	UP	dn	dn	dn	dn
16	dn	UP	UP	UP	UP
17	dn	UP	UP	UP	dn
18	dn	UP	UP	dn	UP
19	dn	UP	UP	dn	dn
20	dn	UP	dn	UP	UP
21	dn	UP	dn	UP	dn
22	dn	UP	dn	dn	UP
23	dn	UP	dn	dn	dn
24	dn	dn	UP	UP	UP
25	dn	dn	UP	UP	dn
26	dn	dn	UP	dn	UP
27	dn	dn	UP	dn	dn
28	dn	dn	dn	UP	UP
29	dn	dn	dn	UP	dn
30	dn	dn	dn	dn	UP
31	dn	dn	dn	dn	dn

BIT VALUE: 16 8 4 2 1

5701 Panic Xmtr.

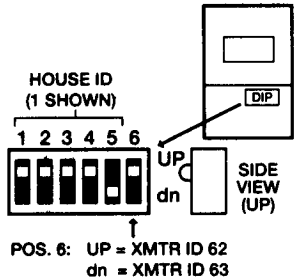

5727 Keypad

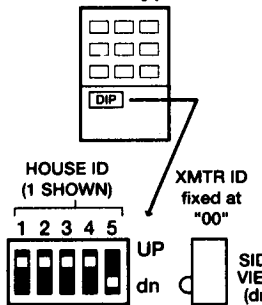

5706/5707 Smoke Detector Transmitter

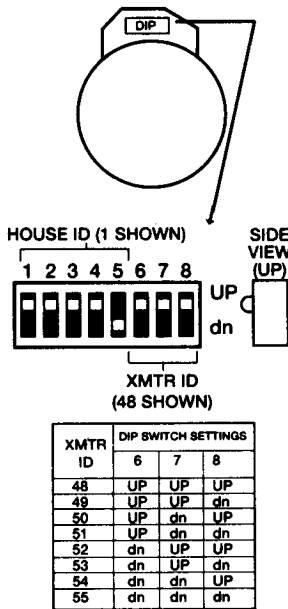

5775 PIR Detector/Transmitter

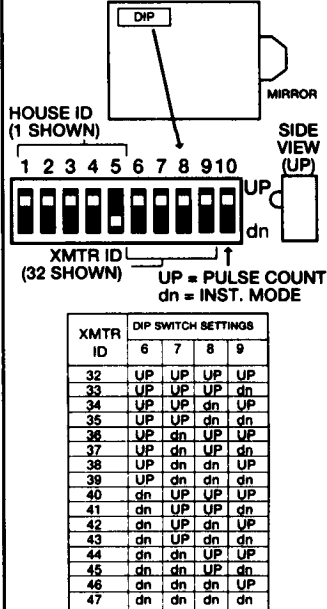

5715 Universal Xmtr.

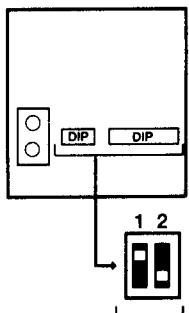

5711/5711WM Door/Window Transmitter

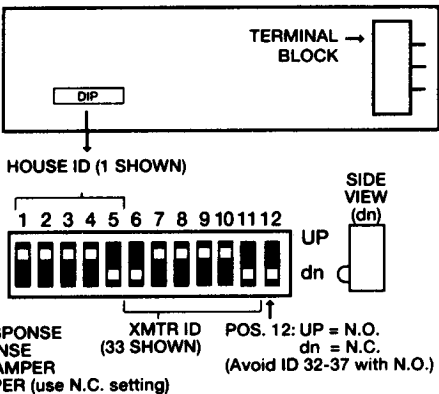

POS. 1: UP = NORMAL RESPONSE
dn = FAST RESPONSE
POS. 2: UP = NO COVER TAMPER
dn = COVER TAMPER (use N.C. setting)

POS. 12: UP = N.O.
dn = N.C.
(Avoid ID 32-37 with N.O.)

XMTR ID	DIP SWITCH SETTINGS					
	6	7	8	9	10	11
1	UP	UP	UP	UP	UP	dn
2	UP	UP	UP	UP	dn	UP
3	UP	UP	UP	UP	dn	dn
4	UP	UP	dn	UP	UP	UP
5	UP	UP	dn	UP	dn	UP
6	UP	UP	dn	UP	dn	dn
7	UP	UP	dn	dn	UP	UP
8	UP	UP	dn	dn	UP	dn
9	UP	UP	dn	dn	UP	dn
10	UP	UP	dn	dn	dn	UP
11	UP	UP	dn	dn	dn	dn
12	UP	dn	UP	UP	UP	UP
13	UP	dn	UP	UP	UP	dn
14	UP	dn	UP	dn	UP	UP
15	UP	dn	UP	dn	dn	UP
16	UP	dn	UP	dn	dn	dn
17	UP	dn	dn	UP	UP	UP
18	UP	dn	dn	UP	UP	dn
19	UP	dn	dn	UP	dn	UP
20	UP	dn	dn	UP	dn	dn
21	UP	dn	dn	dn	UP	UP
22	UP	dn	dn	dn	UP	dn
23	UP	dn	dn	dn	dn	UP
24	UP	dn	dn	dn	dn	dn
25	UP	dn	dn	dn	dn	dn
26	UP	dn	dn	dn	dn	dn
27	UP	dn	dn	dn	dn	dn
28	UP	dn	dn	dn	dn	dn
29	UP	dn	dn	dn	dn	dn
30	UP	dn	dn	dn	dn	dn
31	UP	dn	dn	dn	dn	dn
32	UP	UP	UP	UP	UP	UP

BIT VALUE: 32 16 8 4 2 1

XMTR ID	DIP SWITCH SETTINGS					
	6	7	8	9	10	11
33	dn	UP	UP	UP	UP	dn
34	dn	UP	UP	UP	dn	UP
35	dn	UP	UP	UP	dn	dn
36	dn	UP	UP	dn	UP	UP
37	dn	UP	UP	dn	UP	dn
38	dn	UP	UP	dn	dn	UP
39	dn	UP	UP	dn	dn	dn
40	dn	UP	dn	UP	UP	UP
41	dn	UP	dn	UP	UP	dn
42	dn	UP	dn	UP	dn	UP
43	dn	UP	dn	UP	dn	dn
44	dn	UP	dn	dn	UP	UP
45	dn	UP	dn	dn	UP	dn
46	dn	UP	dn	dn	dn	UP
47	dn	UP	dn	dn	dn	dn
48	dn	dn	UP	UP	UP	UP
49	dn	dn	UP	UP	UP	dn
50	dn	dn	UP	UP	dn	UP
51	dn	dn	UP	UP	dn	dn
52	dn	dn	UP	dn	UP	UP
53	dn	dn	UP	dn	UP	dn
54	dn	dn	UP	dn	dn	UP
55	dn	dn	UP	dn	dn	dn
56	dn	dn	dn	UP	UP	UP
57	dn	dn	dn	UP	UP	dn
58	dn	dn	dn	UP	dn	UP
59	dn	dn	dn	UP	dn	dn
60	dn	dn	dn	dn	UP	UP
61	dn	dn	dn	dn	UP	dn
62	dn	dn	dn	dn	dn	UP
63	dn	dn	dn	dn	dn	dn

BIT VALUE: 32 16 8 4 2 1

5716 Door/Window Transmitter

IMPORTANT SET SWITCHES WITH BATTERY REMOVED

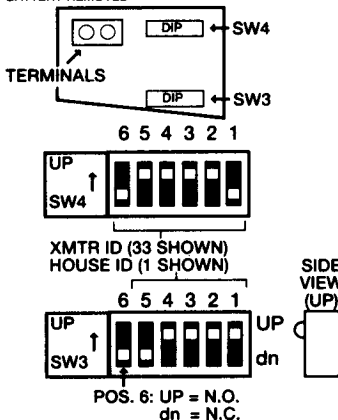

POS. 6: UP = N.O.
dn = N.C.

HOUSE ID	DIP SWITCH SETTINGS			
	5	4	3	2
1	dn	UP	UP	UP
2	UP	dn	UP	UP
3	dn	dn	UP	UP
4	UP	dn	UP	UP
5	dn	UP	dn	UP
6	UP	dn	dn	UP
7	dn	dn	dn	UP
8	UP	UP	UP	dn
9	dn	UP	UP	dn
10	UP	dn	UP	dn
11	dn	dn	UP	dn
12	UP	UP	dn	UP
13	dn	UP	dn	UP
14	UP	dn	dn	UP
15	dn	dn	dn	UP
16	UP	UP	UP	dn
17	dn	UP	UP	dn
18	UP	dn	UP	dn
19	dn	dn	UP	dn
20	UP	UP	dn	UP
21	dn	UP	dn	UP
22	UP	dn	dn	UP
23	dn	dn	dn	UP
24	UP	UP	UP	dn
25	UP	UP	UP	dn
26	UP	dn	UP	dn
27	dn	dn	UP	dn
28	UP	UP	dn	dn
29	dn	UP	dn	dn
30	UP	dn	dn	dn
31	dn	dn	dn	dn

BIT VALUE: 1 2 4 8 16

5716 Door/Window Transmitter

TRANSMITTER ID	DIP SWITCH SETTINGS				
	6	5	4	3	2
1	dn	UP	UP	UP	UP
2	UP	dn	UP	UP	UP
3	dn	dn	UP	UP	UP
4	UP	UP	dn	UP	UP
5	dn	UP	dn	UP	UP
6	UP	dn	dn	UP	UP
7	dn	dn	dn	UP	UP
8	UP	UP	UP	dn	UP
9	dn	UP	UP	dn	UP
10	UP	dn	UP	dn	UP
11	dn	dn	UP	dn	UP
12	UP	UP	dn	dn	UP
13	dn	UP	dn	dn	UP
14	UP	dn	dn	dn	UP
15	dn	dn	dn	dn	UP
16	UP	UP	UP	UP	UP
17	dn	UP	UP	UP	UP
18	UP	dn	UP	UP	UP
19	dn	dn	UP	UP	UP
20	UP	UP	dn	UP	UP
21	dn	UP	dn	UP	UP
22	UP	dn	dn	UP	UP
23	dn	dn	dn	UP	UP
24	UP	UP	UP	dn	UP
25	dn	UP	UP	dn	UP
26	UP	dn	UP	dn	UP
27	dn	dn	UP	dn	UP
28	UP	UP	dn	dn	UP
29	dn	UP	dn	dn	UP
30	UP	dn	dn	dn	UP
31	dn	dn	dn	dn	UP
32	UP	UP	UP	UP	UP
33	dn	UP	UP	UP	UP
34	UP	dn	UP	UP	UP
35	dn	dn	UP	UP	UP
36	UP	UP	dn	UP	UP
37	dn	UP	dn	UP	UP
38	UP	dn	dn	UP	UP
39	dn	dn	dn	UP	UP
40	UP	UP	UP	dn	UP
41	dn	UP	UP	dn	UP
42	UP	dn	UP	dn	UP
43	dn	dn	UP	dn	UP
44	UP	UP	dn	dn	UP
45	dn	UP	dn	dn	UP
46	UP	dn	dn	dn	UP
47	dn	dn	dn	dn	UP
48	UP	UP	UP	UP	dn
49	dn	UP	UP	UP	dn
50	UP	dn	UP	UP	dn
51	dn	dn	UP	UP	dn
52	UP	UP	dn	UP	dn
53	dn	UP	dn	UP	dn
54	UP	dn	dn	UP	dn
55	dn	dn	dn	UP	dn
56	UP	UP	UP	dn	dn
57	dn	UP	UP	dn	dn
58	UP	dn	UP	dn	dn
59	dn	dn	UP	dn	dn
60	UP	UP	dn	dn	dn
61	dn	UP	dn	dn	dn
62	UP	dn	dn	dn	dn
63	dn	dn	dn	dn	dn

BIT VALUE: 1 2 4 8 16 32

Note: For a 5827 (5800 System) Wireless Keypad, House ID settings are opposite to those for a 5727 (i.e., "UP" is "dn" and "dn" is "UP").

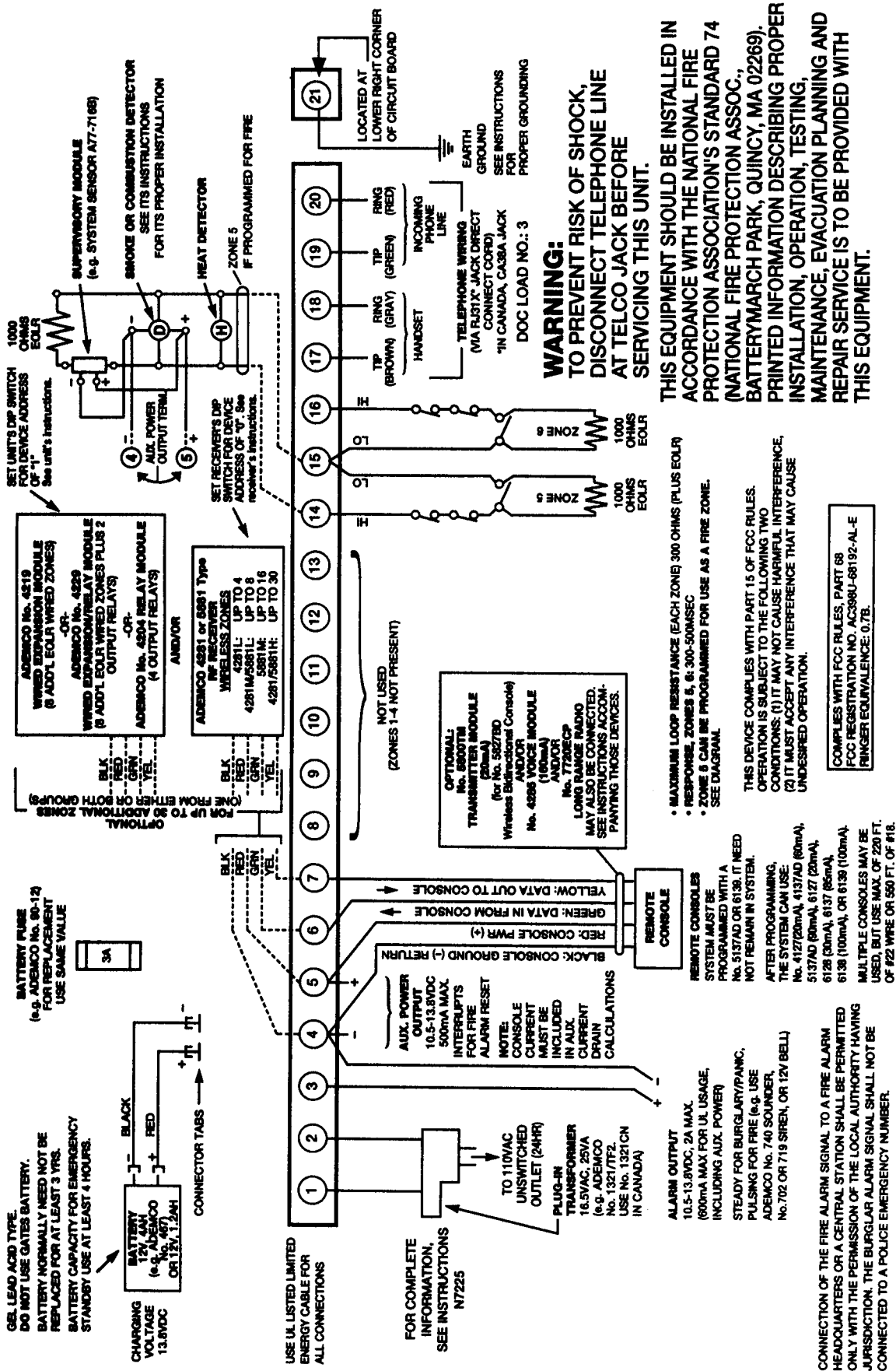

Ademco via30+

SUMMARY OF CONNECTIONS

INDEX

- 1321/TF2, 39, 41
- 1321CN, 39, 41
- 4127, 4, 39
- 4130PC, 27
- 4137AD, 4, 39
- 4204, 4, 5, 11, 12, 40
- 4219, 4, 5, 7, 12, 40
- 4229, 4, 5, 7, 11, 12, 40
- 4281, 4, 5, 9
- 4281H, 5, 8, 40
- 4281L, 5, 8, 40
- 4281M, 5, 8, 40
- 4285, 4, 13, 18, 27, 28, 29, 41
- 5137AD, 4, 16, 39
- 5700, 8
- 5701, 8, 41
- 5706, 41
- 5707, 41
- 5711, 41
- 5715WH, 41
- 5716, 41
- 5716WM, 41
- 5727, 4, 8, 42
- 5742, 41
- 5743, 41
- 5775, 42
- 5800, 8
- 5800TM, 40, 42, 43
- 5801, 4, 9, 22, 42
- 5802, 4, 8, 35, 42
- 5802CP, 8, 35
- 5802MN, 42
- 5803, 4, 8, 9, 35, 42
- 5806, 42
- 5807, 42
- 5816, 9, 43
- 5817, 43
- 5818, 43
- 5827, 4, 8, 9, 43, 46
- 5827BD, 4, 8, 9, 42, 43
- 5849, 43
- 5881, 4, 5, 9
- 5881H, 5, 8, 40
- 5881L, 5, 8, 40
- 5881M, 5, 8, 40
- 5890, 43
- 6127, 4, 40
- 6128, 4, 40
- 6137, 4, 40
- 6138, 4, 40
- 6139, 4, 16, 40
- 7720ECP, 13, 18, 41
- A -**
- A77-716B EOL Relay Module, 6
- "AC" Display, 17
- "AC LOSS" Display, 35
- Account. No., 19
- Action (A), 24, 25
- Additional Wired Zones, 5, 7
- Addressable Consoles, 4, 14
- Alarm Sounding, 18
- Alpha Descriptors, 27
- Arming, 34
- Arming Ding, 19
- ASCII Chart, 29
- B -**
- "BAT" Display, 35
- Battery, 15, 35, 39
- Bell Timeout, 18
- Bypassing Zones, 34
- C -**
- "CA" Display, 35
- Cabinet, 12
- "CANCELED ALARM" Display, 35
- "CC" Display, 35
- "CHECK" Display, 8, 35
- Chime Mode, 34
- Communication, 4
- Connections and Terminals, 14, 47
- Consoles, 4
- Contact ID Format, 31
- Control's Circuit Board, 12
- CSFM, 49
- Custom Alpha Editing, 22, 26
- Custom Words, 28, 29
- D -**
- Data Fields, 18
- Defaults, 17
- Dialer Delay, 19
- Dictionary, 29
- DIP Switch Setting
 - 4204, 11
 - 4219, 7
 - 4229, 7, 11
 - 4281, 8
 - 5881, 8
- DIP Switch Tables for 5700 RF System Devices, 46
- Disarming, 34
- "dl" Display, 17, 35
- Downloading, 10, 17, 26, 32
- Duress, 5
- E -**
- "E4" Display, 17
- "E8" Display, 17
- "EA" Display, 35
- Earth Ground, 14
- "EE" Display, 17
- Entry Delay, 18
- EOLR Fire Zone 5), 6
- EOLR Supervised, 4, 5, 6, 7
- Event (EV), 24, 25
- "EXIT ALARM" Display, 35
- Exit Alarm, 35
- Exit Delay, 18
- Exit Warning, 18
- Expansion/Relay Module, 4, 7, 18
- F -**
- "FC" Display, 35
- FCC, 39, 48
- Fire Sounder, 18
- Fire Zone 5), 6
- Forced Bypass, 18
- Formats, 19, 23, 30, 39
- G -**
- Go/No Go Test, 9, 36
- Grounding, 14
- H -**
- Hard Wired Zones, 6
- House ID, 9, 18
- I -**
- Input Device Type (In), 21
- Input IDs (Loop Codes), 9, 10, 22, 26, 42
- K -**
- Keypad, 9, 33
- L -**
- Learning RF Input (L), 9, 10, 22
- Lock, 12
- Long Range Radio, 4, 13, 18
- Low Battery Signal, 8, 35
- M -**
- Master Code, 4, 16, 17, 18, 33, 36
- Modem, 32
- Multiple Consoles, 4, 14
- N -**
- N.O. and/or N.C. Sensors, 5, 6
- "NO AC" Display, 35
- "NOT READY" Display, 17, 36
- O -**
- "OC" Display, 17, 35
- Output Relay Examples, 44
- Output Relay Modules, 4, 11, 18, 24, 26, 40
- Also see 4204, 4229*
- P -**
- PABX, 19
- Panic, 5, 34
- Phone Lines, 4
- Phone No., 19
- Phone System, 19
- PIRs, 5, 9, 42, 43
- Power Failure, 35
- Power-up, 15, 17
- Programming, 4, 16, 17, 18
- Q -**
- Quick Arm, 18, 33
- R -**
- Radionics, 19
- "READY" Display, 17, 36
- Receivers, 4, 5, 8, 9, 13, 40
- Receiver's DIP Switch, 8
- Relay Basics, 24
- Relay Displays, 25
- Relay Outputs, 4, 11, 34
- Remote Consoles, 4
- Report Codes (RC), 20, 21, 23, 30
- Reporting Formats, 19, 23, 30, 39
- Response Time, 5, 6
- Response Type, 6, 20
- RF Interference, 9
- RF System Type, 8, 18
- S -**
- Secondary User Codes, 4, 33
- Security Codes, 33
- Serial Numbers, 9, 10, 26
- SESCOA, 19
- Smoke Detectors, 5, 6, 11
- Sniffer Mode, 9, 36, 37
- Start/Stop Relay, 24
- Supervised Fire, 6
- Supervised Transmitters, 8, 21, 42
- "System Busy" Display, 17
- T -**
- Tamper, 5, 8
- Terminals and Connections, 14, 47
- Test Message, 19
- Testing, 36
- Three minute Lock-out, 9, 43
- Transformer, 14, 39
- Transmitters, 8, 9, 10, 37, 42, 43
- Trouble Conditions, 35
- Troubleshooting, 37
- U -**
- Unsupervised Transmitters, 8, 21, 42
- "UR" Display, 8
- User Codes, 4, 33
- V -**
- Voice Module 4, 13, 18, 27, 28, 29, 41
- W -**
- Wired Zones
 - Basic, 4, 5, 6
 - Expansion, 4, 5, 7
- Wireless Zones, 4, 5, 8
- Wireless Expansion, 4, 5, 8
- Wireless Keypad, 8, 42, 43
- Z -**
- Zone Assignment, 20
- Zone Characteristics, 5
- Zone Descriptors, 27
- Zone List (ZL), 11, 24, 25, 26
- Zone Resistance, 6
- Zone Type/System Operation (ZT), 24, 25
- Zones
 - Zones 5, 6), 5, 6
 - Zones 7, 95, 96), 5
 - Zone 8), 5
 - Zone 9), 5